

APPLYVRAC® eterniti®

Gourmet
& zero
waste

Eco-responsible solutions

that are naturally appealing!

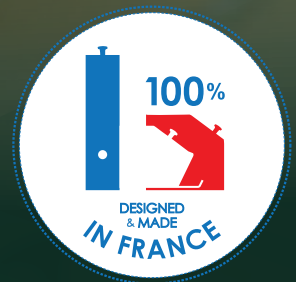

dispensers & display stands
for serving bulk products
- buffets and shared spaces -



The APPLYVRAC® Eterniti® range _ p.3

Muesli bar _ p.5

Small display case _ p.7

Tea counter _ p.8

Large display case _ p.9

Scoop dispensers _ p.10

Scoop dispenser corner stands _ p.12

Accessories scoop dispenser corner stands _ p.14

Gravity dispensers _ p.15

Gravity dispenser corner stands _ p.17

Bulk corner cabinet _ p.19

About APPLYMAGE® _ p.21



Where and how are the products made?

The products in the APPLYVRAC[®] Eterniti[®] range are **entirely designed and manufactured in France**, in the Lyon region, using the **best conventional machining** techniques and a **short supply chain** and local economy approach.

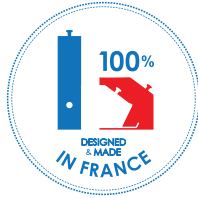

What does it include?

The APPLYVRAC[®] Eterniti[®] range is made up of eco-designed dispensers (gravity dispensers, scoop dispensers, display cases) and display stands (muesli bar, corner stands). It is constantly evolving to adapt to the **changing needs of hospitality and public sector professionals** (shared spaces, coworking/coliving spaces, dining facilities, etc.).

Which requirements do the products meet?

Food-grade compliance

The materials used to make the products in the APPLYVRAC[®] Eterniti[®] range are naturally **recyclable**. They are approved for contact with food and free from both BPA and phthalates. These physiologically safe **materials** are all **certified according to the standards in force and the latest food regulations** (analyses and tests carried out by several independent French and foreign laboratories).

Materials approved and certified for **contact with food** pursuant to the **standards and regulations in force**

The knobs of our dispensers are treated against **germs, bacteria, viruses and coronaviruses** including Covid-19

Hygiene

The **excellent airtightness** of these dispensers, as well as the antimicrobial treatment used for coating the service knobs, significantly **reduce health risks**. Many parts have been designed to be easily removable and disassembled to enable **quick and thorough cleaning**.

Sustainability

The materials selected are of **top quality** and extremely impact-resistant, thus ensuring **durability** and a **long lifespan** of the equipment. The **complete repairability** of APPLYVRAC[®] Eterniti[®] dispensers further **extends their lifespan**.

5-year warranty



Main characteristics

of the dispensers

the APPLYVRAC®
eterniti®
range



design combining simplicity, aesthetics and functionality

- clean lines for total transparency
- **excellent product visibility to showcase items** in a neat and original way
- Instant **visual control** helps shopkeepers to:
 - monitor stocks in real time
 - step up the prevention of health risks



installation efficiency and freedom

- **less space taken up** in aisles
- **choice of different corner stands:** specific display stands or cabinets ready to install with integrated dispensers
- **installation possible on all kinds of furniture**



control and pleasure of self-service

- **intuitive to use:**
 - flap that opens gradually
 - reduced waste thanks to the gravity dispensers' safety lock
 - lid that slides downwards on scoop dispensers
- **perfect stability:**
 - safety during handling
- **easy to fill**

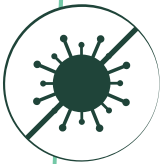

enhanced hygiene

- **easy cleaning** and maintenance:
 - many parts are removable or extractable (including the gravity dispenser spout for regular and rapid cleaning)
 - dispensers are lightweight and sturdy, so they can be cleaned manually with vigour
 - can be placed in professional dishwashers
- **excellent airtightness:**
 - gravity dispensers have a lock and dual-flap system, which helps to reduce health risks
 - scoop dispensers have airtight lids
- **contact area restricted to release knobs** during service:
 - knobs are treated against germs, bacteria, viruses and coronaviruses (including Covid-19)
 - scoop dispensers can be opened without touching the inside of the lid



exceptional durability

- the materials used are of **top quality** and **extremely impact-resistant**
 - they are guaranteed to be sturdy and last an extremely long time
- **extended life span** of the products:
 - total, simple and fast repairability
 - all components can be replaced by the user
 - assembly is fully mechanical with stainless steel crosspieces (no gluing or welding) / no plastic injection-moulded parts
 - reduction in waste as well as logistical and transport constraints (reduced carbon footprint)
- **5-year contractual warranty**



possibility of customisation and tailor-made items

- **in-house design office**
- **adaptation of an existing project** or **a project from A to Z**
 - according to specifications defined with the client

MUESLI BAR

also suitable for a
SELECTION OF TOPPINGS

This display stand has been specially designed to offer the **WIDEST SELECTION OF SEEDS**, nuts, dried fruits, chocolate chips and other ingredients for a **COMPLETE MUESLI**, all within a compact space.

MODULAR and requiring no special installation, it will always find its place on a breakfast buffet or in a shared space.

What products are they suitable for?

Ideal for **seeds, nuts, small dried fruits** (such as raisins, cranberries, etc.), chocolate chips, confectionery, etc.

spoon service
in small quantities



500-ml airtight bottles
with integrated stainless steel spoons
and double labelling

removable rear blackboard (optional)

service plate included

Highly durable **BOROSILICATE GLASS** bottles with wooden lids and seals for **EXCELLENT AIRTIGHTNESS**.



Extended life span



Total reparability



Perfectly airtight bottles



Knobs treated
against germs

removable
blackboard-style
rear panel
(optional)

x6
bottles



x10
bottles

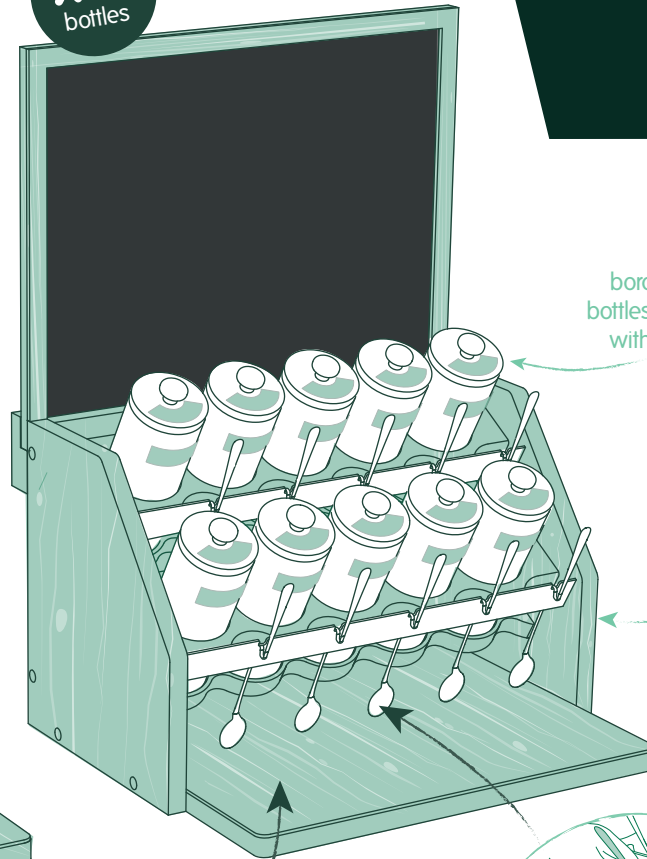

borosilicate glass
bottles + wooden lids
with airtight seals

solid wood
structure



double labelling

- reduces the risk of mixing products
- guarantees excellent visibility for customers
- blank, erasable labels provided

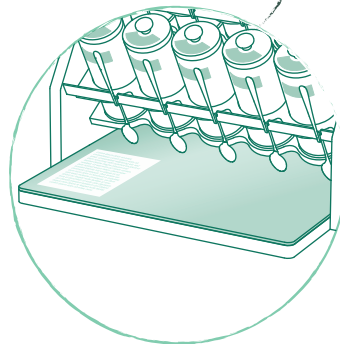

service and protection plate

- transparent and removable
- quick and easy to clean on a daily basis
- possibility to slide detailed information sheets underneath
- protection for the wooden base

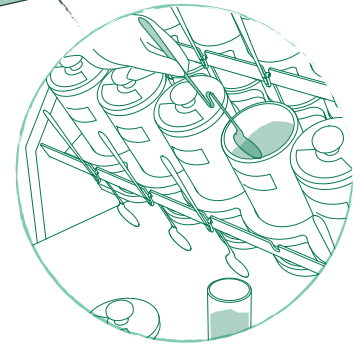

spoon service

- stainless steel spoons integrated into the display stand
- 1 spoon per bottle
- precise service in small quantities

**15-bottle model
available on request**

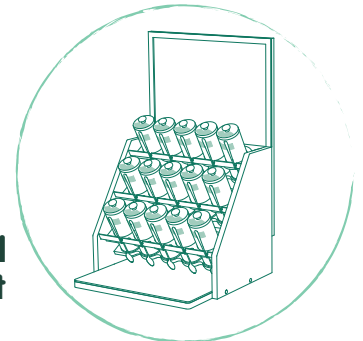

• Dimensions (in mm)

6-reference model: 300 (w.) x 362 (h.) x 380 (d.)
with rear panel: 460 (w.) x 520 (h.) x 415 (d.)

10-reference model: 460 (w.) x 362 (h.) x 380 (d.)
with rear panel: 460 (w.) x 635 (h.) x 415 (d.)

15-reference model: 460 (w.) x 467 (h.) x 460 (d.)
with rear panel: 460 (w.) x 750 (h.) x 495 (d.)

• Capacity

500 ml / bottle

• Materials

structure: solid pine wood, plywood (PEFC- and/or FSC-certified), food-safe varnish

bottle: food-grade borosilicate glass, solid wood (PEFC), silicone and stainless steel

spoon: food-grade stainless steel

SMALL DISPLAY CASE

The very elegant 3L APPLYVRAC® Eterniti® display case is ideal for presenting and housing 'TOP PICKS' or VALUABLE PRODUCTS. As it DOES NOT TAKE UP MUCH SPACE, it can be placed anywhere, including in prime positions in sales areas.



What products are they suitable for?

Ideal for **confectionery, dried fruit, snacks, chocolate, appetizer nibbles, etc.**

very large opening:
optimum airtightness

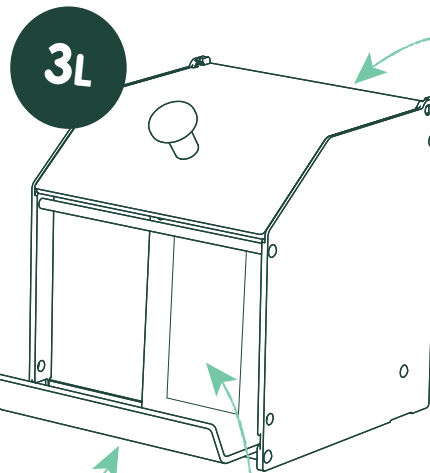

transparent and removable label holder

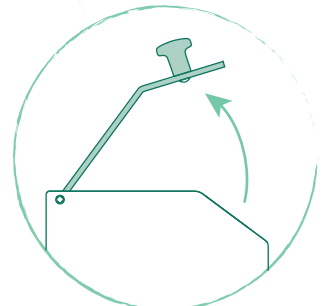

hinged lid

- very large opening
- extractable
- knobs treated against germs

rapid and simple maintenance

thanks to removable lid, front panel and scoop rest

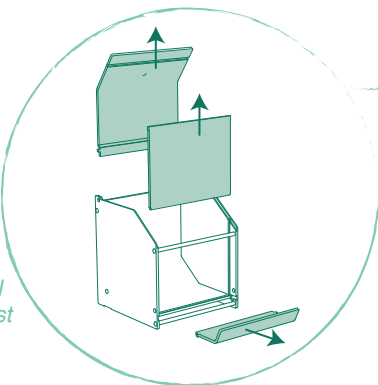

● **Dimensions** (in mm)
170 (w.) x 196 (h.) x 215 (d.)

● **Weight**
approx. 0.9 kg

● **Materials** 🍴

Food-grade recyclable PET-G (without Bisphenol A and phthalates), silicone and stainless steel, solid wood (PEFC)



Extended life span



Total repairability



Lightweight



Knobs treated against germs

TEA COUNTER



This counter can display a **VERY LARGE SELECTION** of tea bags, making it ideal for serving tea/herbal tea on a breakfast buffet or in a shared space.

With its great transparency and three levels, it gives you a **NEAT, ELEGANT** and **PRACTICAL WAY** to display your teas (or herbal teas).

What products are they suitable for?

Ideal for (herbal) tea bags



3-level podium: holds around 156 tea bags

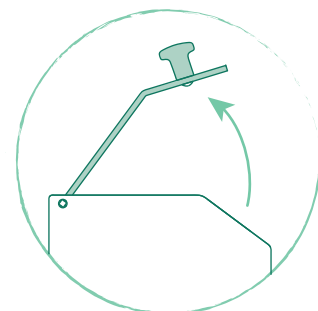

hinged lid

- very large opening
- extractable
- knobs treated against germs

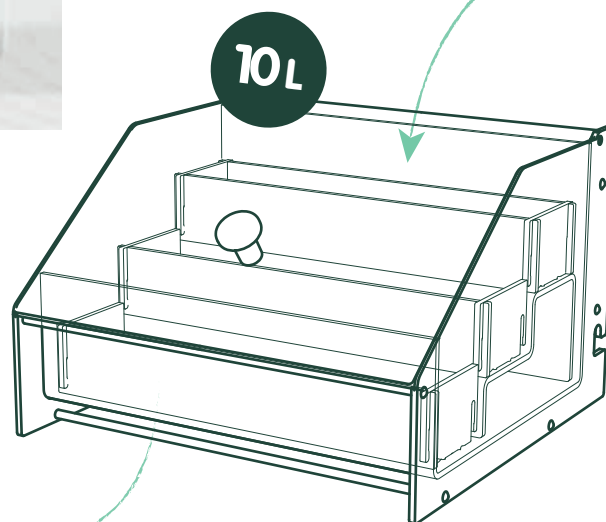

10L

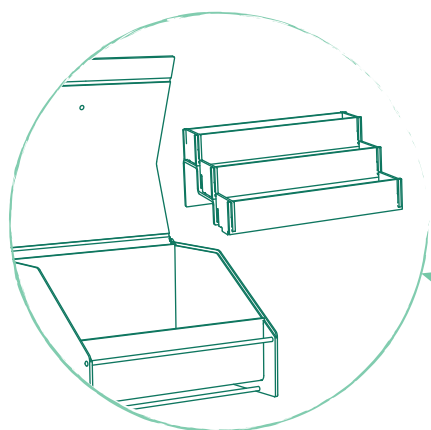

removable & detachable podium

makes cleaning easier

- **Dimensions** (in mm)

312 (w.) x 200 (h.) x 295 (d.)
compartments (inside): 275 (w.) x 50 (h.) x 55-64 (d.)

- **Weight**

approx. 3 kg

- **Materials** 

Food-grade recyclable PET-G (without Bisphenol A and phthalates) and stainless steel, solid wood (PEFC)



Extended life span



Total reparability



Knobs treated against germs

LARGE DISPLAY CASE

With its natural elegance, the APPLYVRAC® Eterniti®, large display case showcases the most commonly used products to perfection.

With a capacity of 15L, it is suitable for presenting **LARGE ITEMS**.

What products are they suitable for?

Ideal for pastries, bread, etc.

very large opening : optimum airtightness



Their removable tongs rest and lid make them particularly **EASY to USE** and **MAINTAIN**.



15L

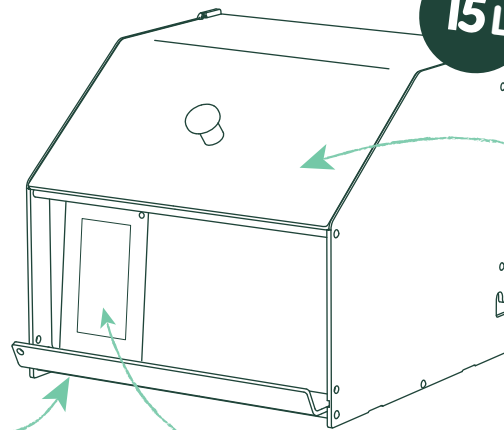

transparent and removable label holder

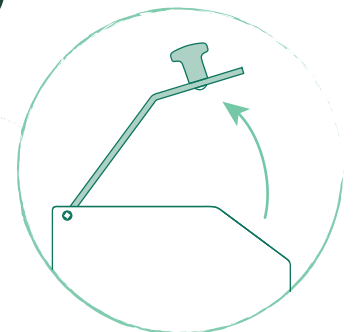

hinged lid

- very large opening
- extractable
- knobs treated against germs

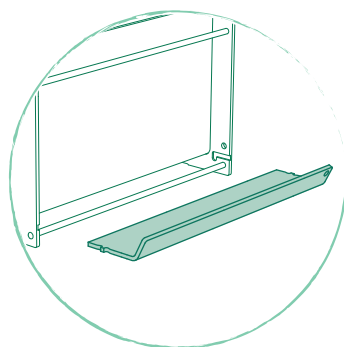

removable tongs rest
makes cleaning easier

● **Dimensions** (in mm)
312 (w.) x 281 (h.) x 327 (d.)

● **Weight**
approx. 2.6 kg

● **Materials** 🛠️

Food-grade recyclable PET-G (without Bisphenol A and phthalates) and stainless steel, solid wood (PEFC)



Extended life span



Total repairability



Knobs treated against germs

SCOOP DISPENSERS

The extremely **AIRTIGHT** and **INCREDIBLY VERSATILE** APPLYVRAC® Eterniti® scoop dispensers can be used for all kinds of food or non-food products.

What products are they suitable for?

Ideal for biscuits, pastries, large cereals, dried fruit, appetizer nibbles, confectionery, etc.

downward sliding opening:
more practical,
more hygienic and
more streamlined

completely transparent for excellent product visibility and promotion

Their extractable scoop holder, top hatch and lid make them **EASY TO FILL** and **CLEAN**.

very easy to clean



Extended life span



Total repairability



Perfectly airtight



Knobs treated against germs

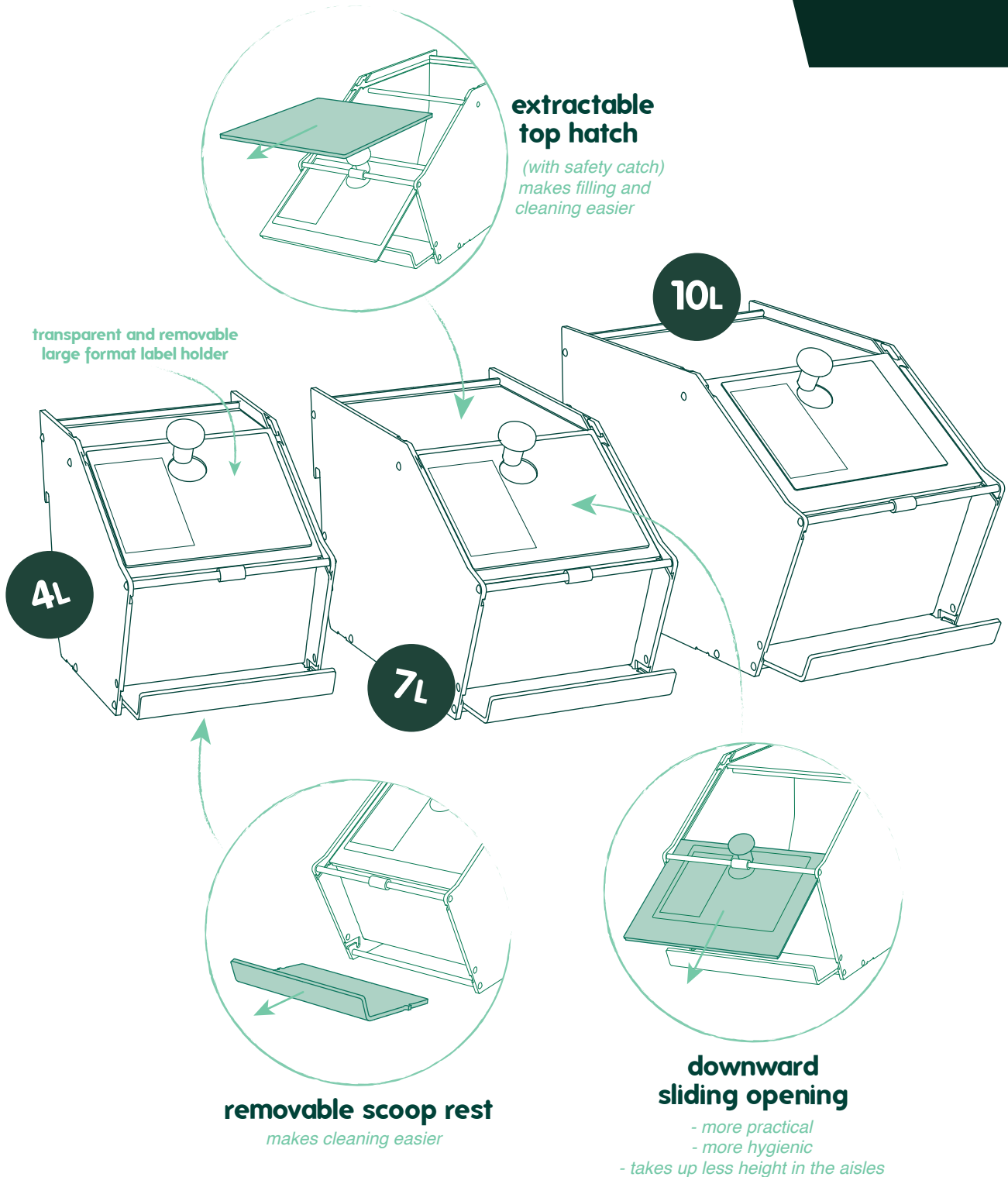

• **Dimensions** (in mm)

4L: 170 (w.) x 217 (h.) x 270 (d.)
7L: 170 (w.) x 217 (h.) x 375 (d.)
10L: 200 (w.) x 250 (h.) x 385 (d.)

• **Materials** 

Food-grade recyclable PET-G (without Bisphenol A and phthalates), silicone and stainless steel, solid wood (PEFC)

• **Weight**

4L: approx. 1.2 kg
7L: approx. 1.6 kg
10L: approx. 2 kg

SCOOP DISPENSER CORNER STANDS

Available in 3 formats, these **CORNER** stands are specially designed for APPLYVRAC® Eterniti® 4L and 7L scoop dispensers.

These **LIGHTWEIGHT** and **MODULAR** stands are particularly suitable for a **QUICK** and **EASY DISPLAY** of scoop dispensers on a breakfast buffet or in a shared space (coliving, coworking space, etc.).

For which use?

Ideal for **quickly setting up** APPLYVRAC® Eterniti® scoop dispensers on a **buffet** or in a **shared space**

perfectly complements the gravity dispenser corner stands



- available in 3 formats for 2, 3 or 4 scoop dispensers
- compatible with the 4L and 7L scoop dispensers

with podium,
for more functions!

The **REAR BLACKBOARD** is **REMOVABLE** and can be replaced with a solid **WOOD PODIUM** (optional accessory) on which you can place items required for serving.



Extended life span



Less space
taken up in aisles



Dispensers are
easy to clean



Knobs treated
against germs

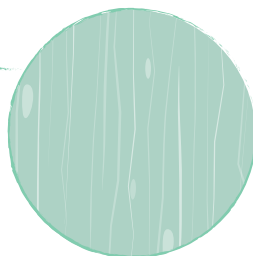
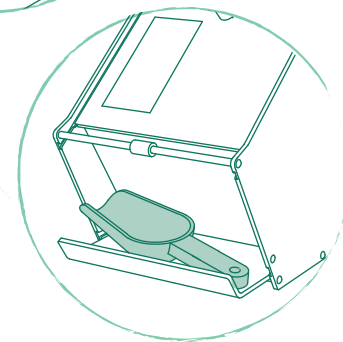
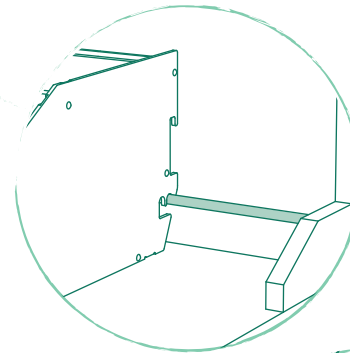
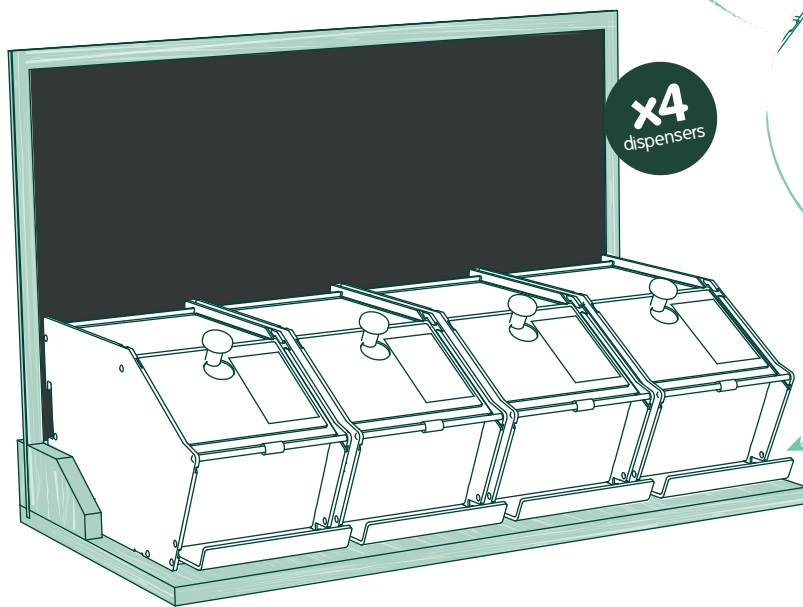
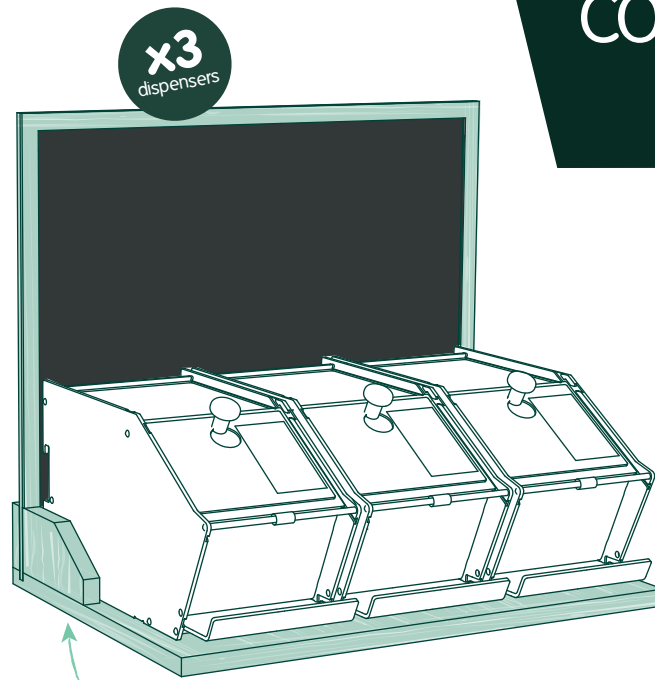
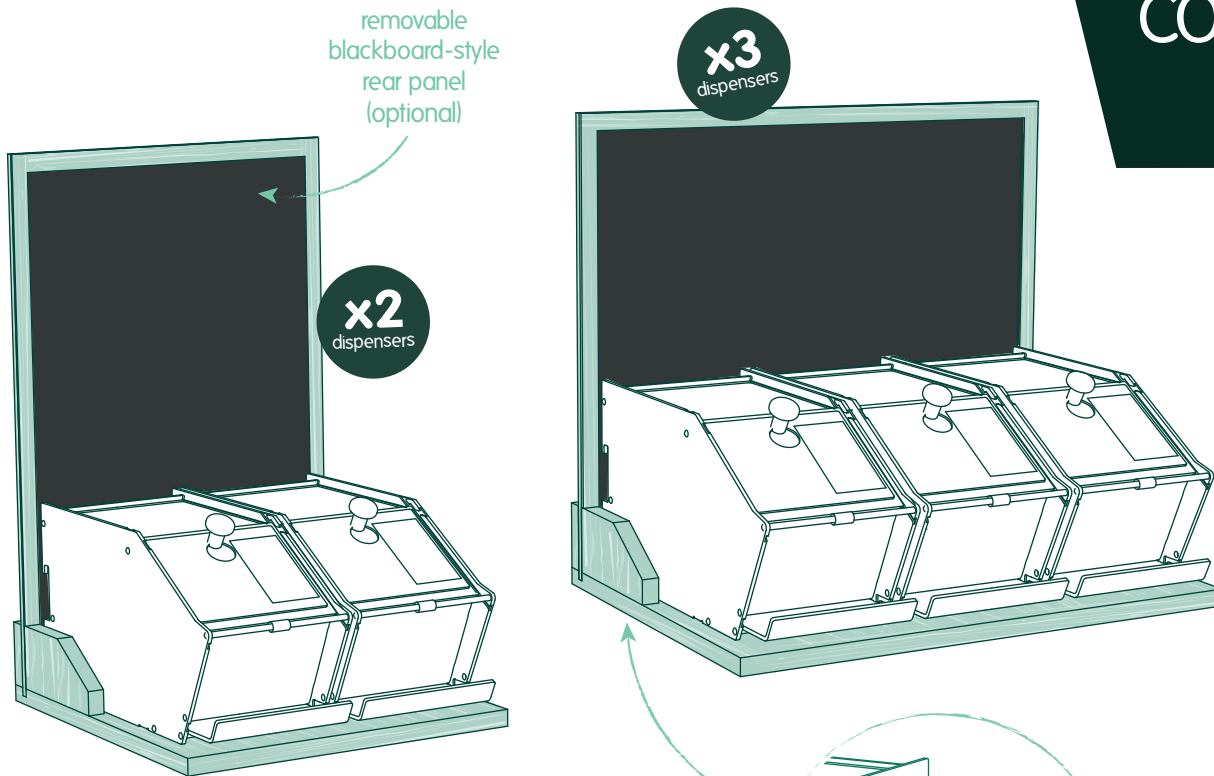

solid wood

- made of PEFC- and/or FSC-certified pine
- made in France
- food-safe varnish

● **Dimensions** (in mm)

x2 scoop dispensers model:

- without scoop dispensers: 381 (w.) x 390 (d.) x 600 (h.)
- with 4L scoop dispensers: 381 (w.) x 390 (d.) x 600 (h.)
- with 7L scoop dispensers: 381 (w.) x 402 (d.) x 600 (h.)

x3 scoop dispensers model:

- without scoop dispensers: 560 (w.) x 390 (d.) x 500 (h.)
- with 4L scoop dispensers: 560 (w.) x 390 (d.) x 500 (h.)
- with 7L scoop dispensers: 560 (w.) x 402 (d.) x 500 (h.)

x4 scoop dispensers model:

- without scoop dispensers: 735 (w.) x 390 (d.) x 500 (h.)
- with 4L scoop dispensers: 735 (w.) x 390 (d.) x 500 (h.)
- with 7L scoop dispensers: 735 (w.) x 402 (d.) x 500 (h.)

● **Materials**

- solid pine wood (PEFC- and/or FSC-certified)
- food-safe varnish

height without blackboard (with dispensers): 222 mm

PODIUM

to place above the scoop dispenser corner stands

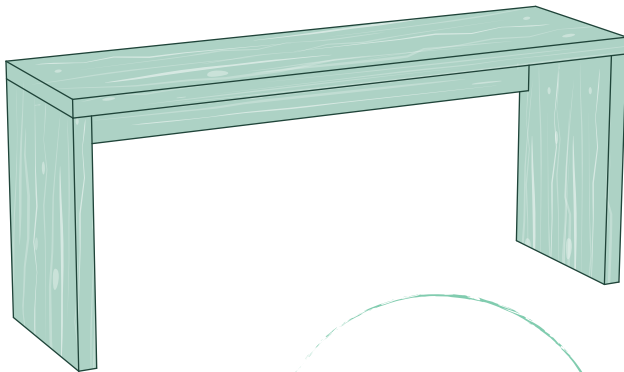

- **Materials**

solid pine wood (PEFC- and/or FSC-certified)
food-safe varnish

- **Dimensions** (in mm)

- podium 60 cm: 601 (w.) x 175 (d.) x 260 (h.)
- podium 78 cm: 776 (w.) x 175 (d.) x 260 (h.)

practical

ideal for storing various items: containers, bowls, utensil box, bags, etc.

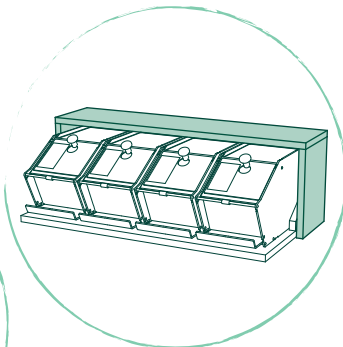
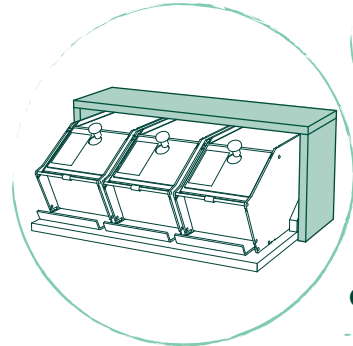

available in 2 formats

- width 60 cm: to place above the x2 or x3 scoop dispenser models
- width 78 cm: to place above the x3 or x4 scoop dispenser models



UTENSILS BOX

open box made of solid wood with 2 compartments

- **Materials**

solid pine wood
(PEFC- and/or FSC-certified)
food-safe varnish

- **Dimensions** (in mm)

170 (w.) x 230 (d.) x 100 (h.)

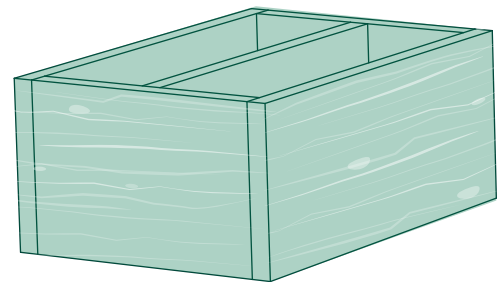

very universal

- ideal for storing various utensils, napkins, bags, etc.
- to be placed freely next to or on the corner stand, on the podium, etc.

GRAVITY DISPENSERS

Thanks to their gentle and gradual **DUAL-FLAP** system, APPLYVRAC® Eterniti® gravity dispensers **DISPENSE JUST THE RIGHT AMOUNT** and offer **GREAT VISIBILITY**.

What products are they suitable for?

Ideal for cereals, seeds, nuts, appetizer nibbles, toppings, etc

dual flap with safety lock for excellent airtightness and 2-stage service

The safety lock **REDUCES WASTE** and health risks.

completely transparent for excellent product visibility and promotion

The extractable parts (lid, front panel, flap and spout) ensure **EFFECTIVE CLEANING**.

very easy to clean



Extended life span



Total repairability



Less space taken up in aisles



Knobs treated against germs

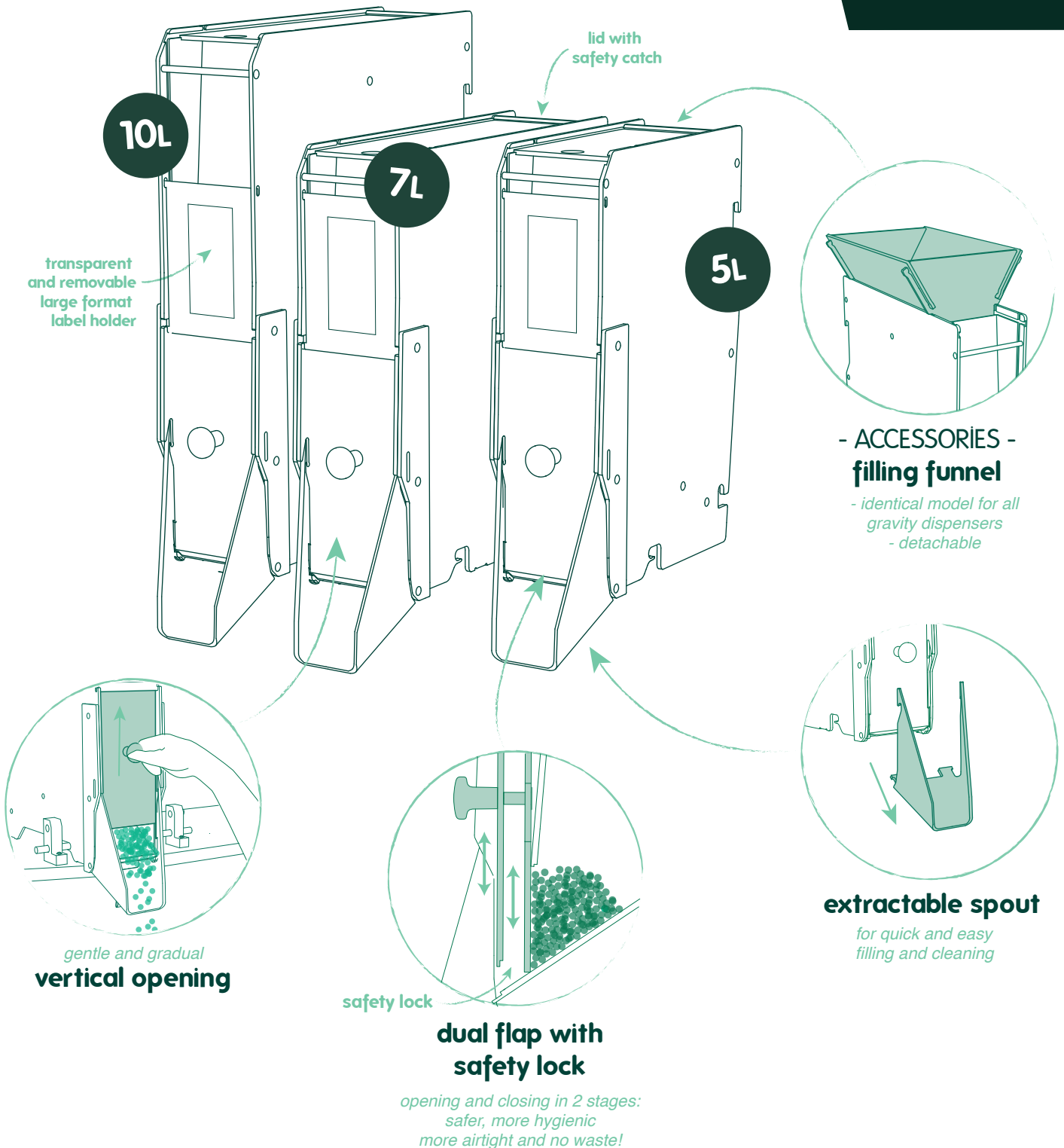

**- ACCESSORIES -
filling funnel**

- identical model for all gravity dispensers
- detachable

extractable spout

for quick and easy filling and cleaning

dual flap with safety lock

opening and closing in 2 stages:
safer, more hygienic
more airtight and no waste!

● **Dimensions** (in mm)

- 5L** overall: 120 (w.) x 457 (h.) x 300 (d.) ⁽¹⁾
(excl. spout: 120 (w.) x 395 (h.) x 278 (d.))
- 7L** overall: 120 (w.) x 457 (h.) x 400 (d.) ⁽²⁾
(excl. spout: 120 (w.) x 395 (h.) x 378 (d.))
- 10L** overall: 120 (w.) x 552 (h.) x 400 (d.) ⁽²⁾
(excl. spout: 120 (w.) x 490 (h.) x 378 (d.))

⁽¹⁾ : min. depth of the furniture unit or shelf: 219 mm
⁽²⁾ : min. depth of the furniture unit or shelf: 319 mm

● **Materials**

Food-grade recyclable PET-G (without Bisphenol A and phthalates), silicone and stainless steel, solid wood (PEFC)

● **Weight**

- 5L**: approx. 2.1 kg
- 7L**: approx. 2.4 kg
- 10L**: approx. 2.9 kg

GRAVITY DISPENSER CORNER STANDS

Available in 2 formats, these **CORNER** stands are specially designed to showcase APPLYVRAC® Eterniti® 5L, 7L and 10L gravity dispensers in an elegant and optimum way.

These **LIGHTWEIGHT** and **MODULAR** stands are particularly suitable for a **QUICK** and **EASY DISPLAY** of gravity dispensers on a breakfast buffet or in a shared space (coliving/coworking space, etc.).

For which use?

Ideal for **quickly setting up** APPLYVRAC® Eterniti® gravity dispensers on a **buffet** or in a **shared space**



free space at the bottom for placing bowls, utensils, napkins, etc.



perfectly complements the scoop dispenser corner stands...

... and muesli bar!

The integrated mounting bar secures the dispensers in place to ensure **SAFE SERVICE**

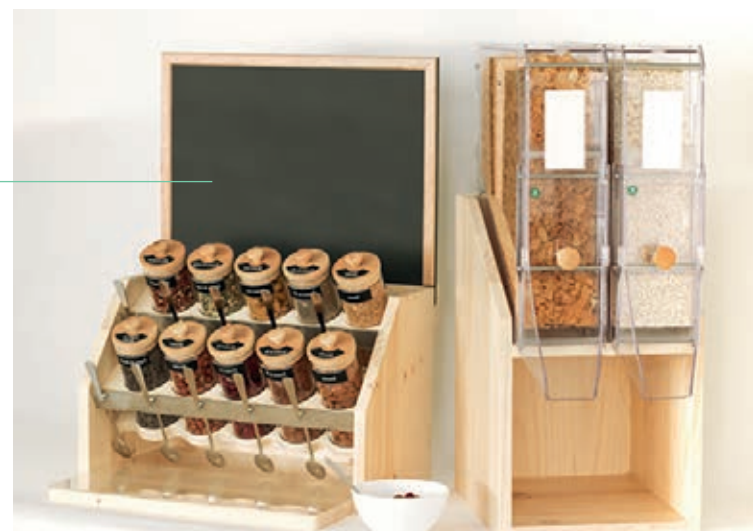

Extended life span



Less space taken up in aisles



Dispensers are easy to clean



Knobs treated against germs

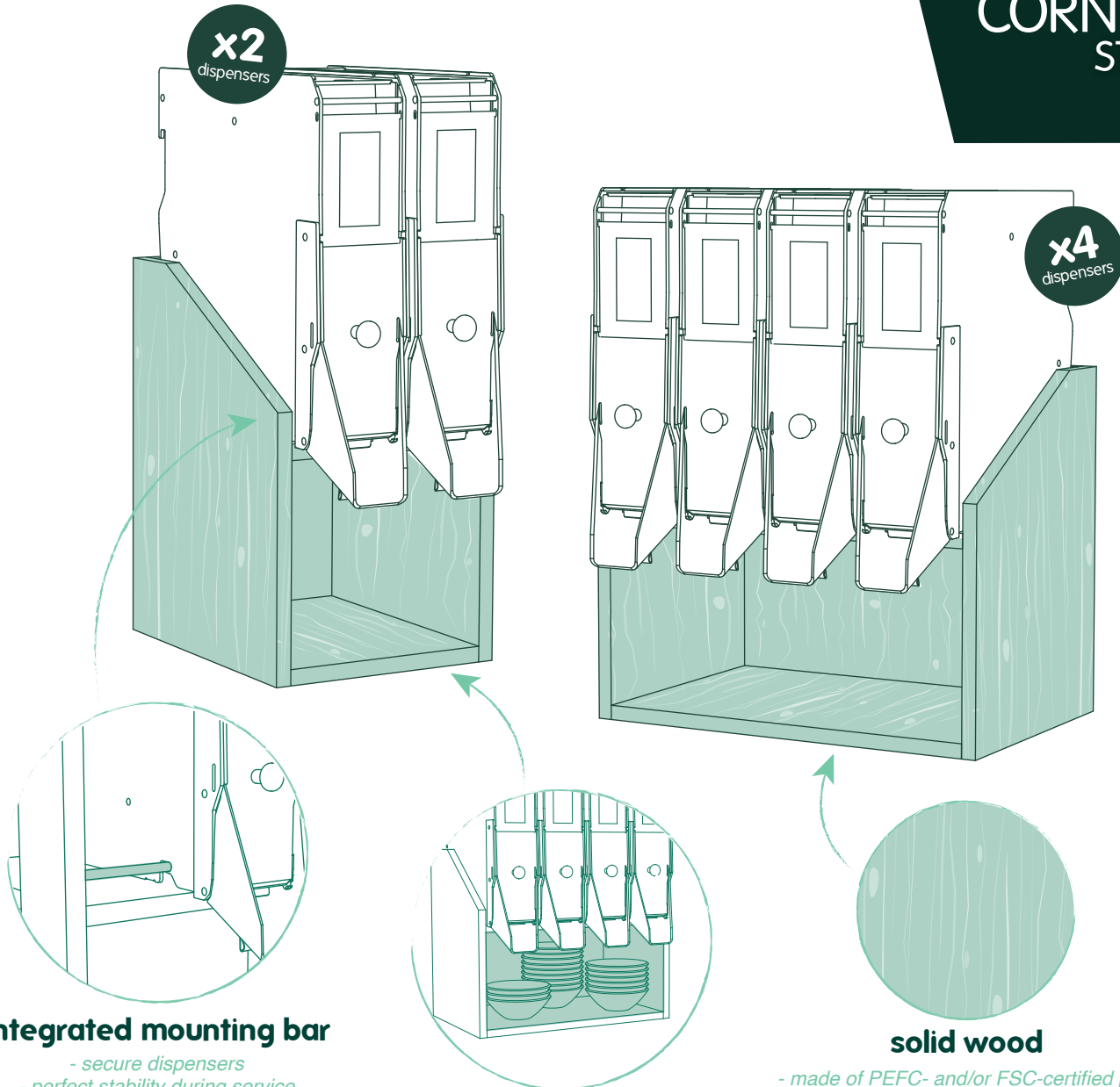

integrated mounting bar

- secure dispensers
- perfect stability during service
- no installation required

free space at the bottom

practical for placing bowls,
napkins, utensils box, etc.

solid wood

- made of PEFC- and/or FSC-certified pine
- made in France
- food-safe varnish

ACCESSORIES

UTENSILS BOX

made of solid wood
with 2 compartments:
**ideal for storing various
utensils, napkins, etc.**

Dimensions (in mm):
170 (w.) x 230 (d.) x 100 (h.)

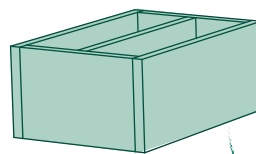

to be placed freely in the
lower free space or
next to the corner stand

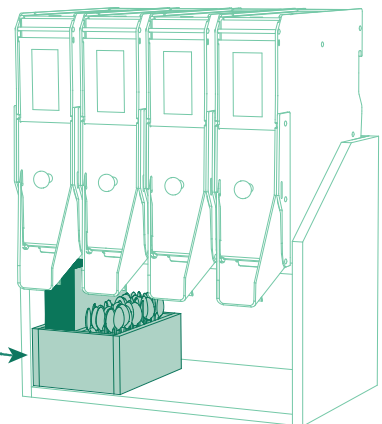

● **Dimensions (in mm)**

x2 dispensers model:

- without gravity dispensers:
281 (w.) x 334 (d.) x 440 (h.)
- with 5L/7L gravity dispensers:
281 (w.) x 416 (d.) x 660 (h.)
- with 10L gravity dispensers:
281 (w.) x 416 (d.) x 755 (h.)

x4 dispensers model:

- without gravity dispensers:
526 (w.) x 334 (d.) x 440 (h.)
- with 5L/7L gravity dispensers:
526 (w.) x 416 (d.) x 660 (h.)
- with 10L gravity dispensers:
526 (w.) x 416 (d.) x 755 (h.)

● **Materials**

solid pine wood (PEFC-
and/or FSC-certified)
food-safe varnish

BULK CORNER CABINET

This cabinet is designed for use with APPLYVRAC® Eterniti® 5L and/or 7L gravity dispensers and 4L and/or 7L scoop dispensers.

With its **CUSTOMISABLE** and **REMOVABLE SIGN**, it is particularly suitable for **SETTING UP A BULK AREA** in a cultural space or shared space (coliving, coworking space, etc.) or for showcasing products from a specific supplier.

For which use?

Ideal for setting up a **functional and space-saving bulk area**

several possible configurations

customisable and removable sign

The integrated mounting bars make it **EASY TO SECURE** the gravity and scoop dispensers.



Extended life span



Less space taken up in aisles



Dispensers are easy to clean



Knobs treated against germs



**customisable
and removable sign**
more installation freedom

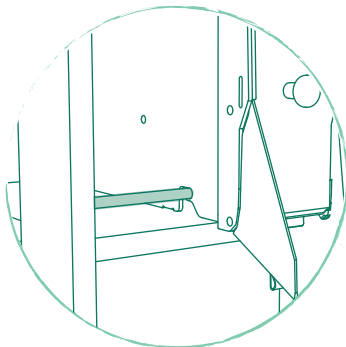

integrated mounting bar
*- secure dispensers
- perfect stability during service*



solid wood
*- made of PEFC- and/or
FSC-certified pine
- made in France
- food-safe varnish*

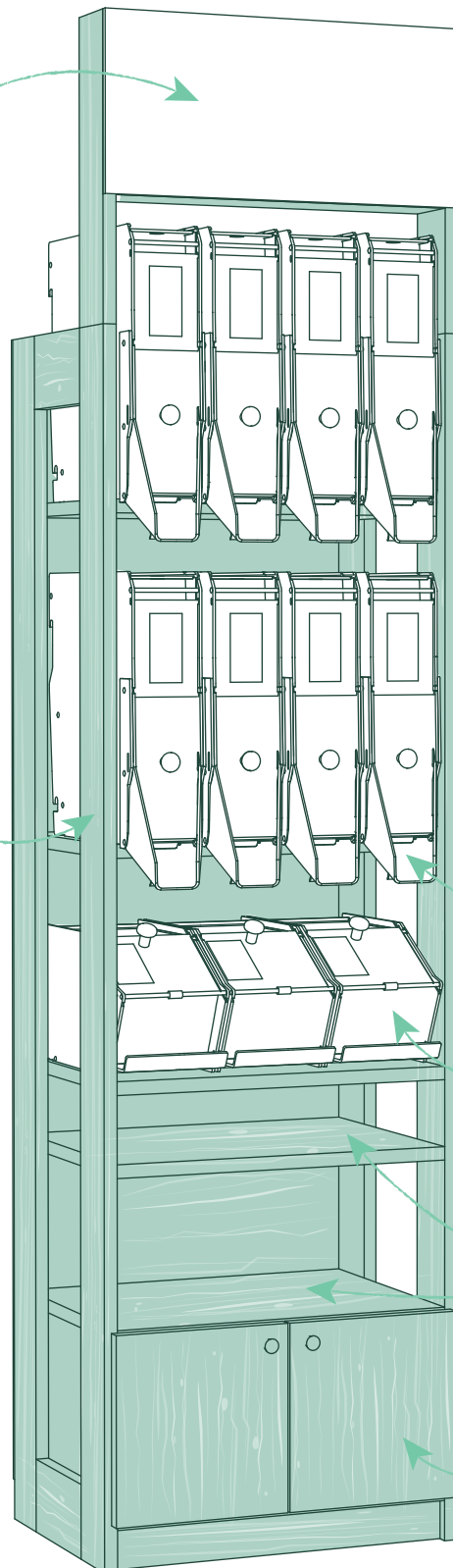

**several possible
configurations:**

- 2 rows of gravity dispensers / 1 row of scoop dispensers
- 1 row of gravity dispensers / 2 rows of scoop dispensers
- 1 row of gravity dispensers / 1 row of scoop dispensers

**1 or 2 rows of
4 x 5L and/or 7L
gravity dispensers**

**1 or 2 rows of
3 x 4L and/or 7L
scoop dispensers**

**free space for bags,
containers or
pre-packaged products**

storage cupboard

➔ don't hesitate to **contact us**
if you have a specific request!

● **Dimensions**

(in mm, with dispensers)

560 (w.) x 2250 (h.) x 450 (d.)
without sign:

560 (w.) x 1950 (h.) x 450 (d.)

● **Capacity**

depending on the configuration:

- 8 x 5L and/or 7L gravity disp. and 3 x 4L and/or 7L scoop disp.
- 4 x 5L and/or 7L gravity disp. and 6 x 4L and/or 7L scoop disp.
- 4 x 5L and/or 7L gravity disp. and 3 x 4L and/or 7L scoop disp.

● **Materials**

solid pine wood (PEFC-
and/or FSC-certified)
food-safe varnish

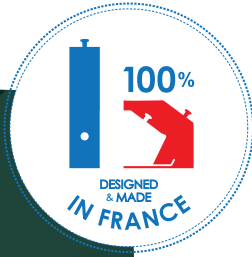

Our expertise

APPLYMAGE®, based in the Lyon region, has been designing and producing **display cases and dispensers** for various business sectors, including the hospitality, convenience store and health sectors, **since 2007**.

With its products, **APPLYMAGE®** aims to **showcase its customers' products** for improved marketing.

APPLYMAGE® products are **distributed** directly or via its customers **across all five continents** in over 80 countries.

Our approach

APPLYMAGE® and its designers – who have received the "Observateur du Design" award several times – are committed to developing **eco-designed** products that are **made in France**, increasingly **innovative** and **built to last**, and which meet user needs as closely as possible.

APPLYMAGE® invests regularly and heavily in **R&D** and **Intellectual Property** to bring new innovations onto the market each year.

registered
brands & trademarks
in France and abroad

OVER **17** years
of **experience**

OVER **40,000**
Applyvac® in service

OVER **600**
establishments
equipped!

Applymage® Eco

APPLYMAGE® Eco, with its **Applyvac®** and **Eterniti®** brands, focuses on developing equipment and solutions intended to improve the layout and dynamism of **hotels** and **collectivities**, retail outlets and homes.

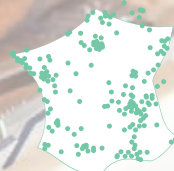

Click here

to see our map of the establishments that have placed their trust in us!



Gourmet
& Zéro
déchet



APPLYMAGE® Eco

✉ 18 rue des Frères Lumière
69680 CHASSIEU - France

☎ +33 (0)9.64.22.06.45
+33 (0)6.73.52.95.77

✉ contact@applymage.com
www.applymage-eco.com

Eco-responsible solutions
that are naturally appealing!

