

APPLYVRAC® eterniti®



Sustainable and aesthetic solutions
for the sale of bulk products



The enticing
way to present
bulk goods

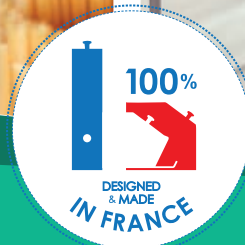

Click on the images to go to the relevant section

The different models | p.4

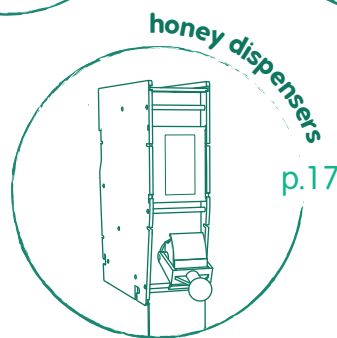
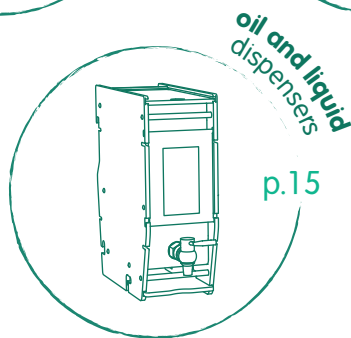
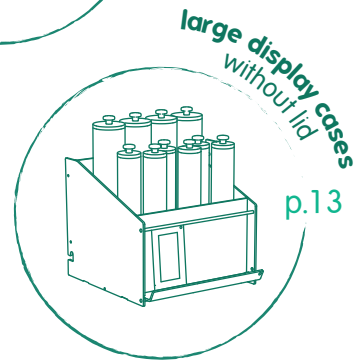
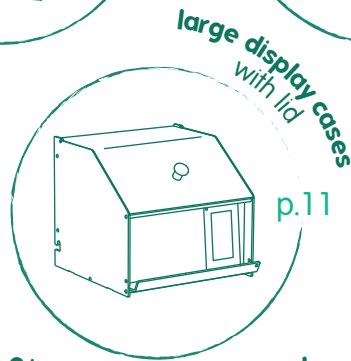
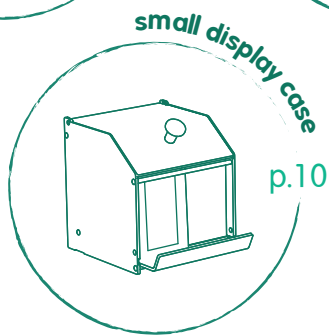
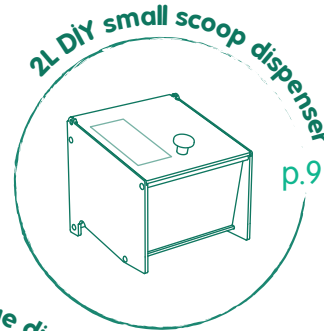
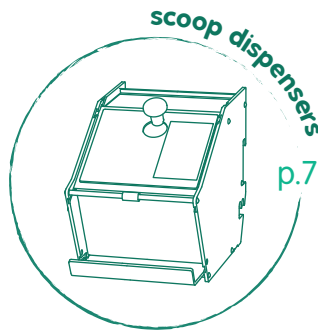
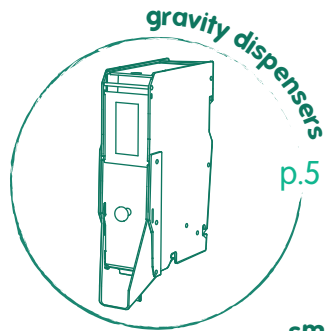

Display stands | p.20

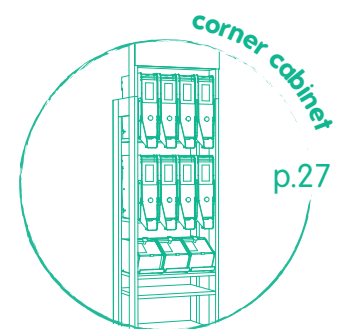
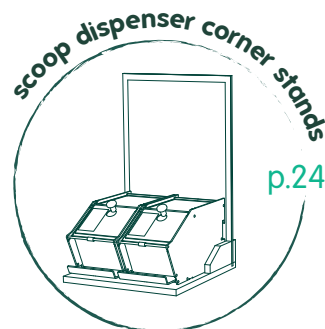
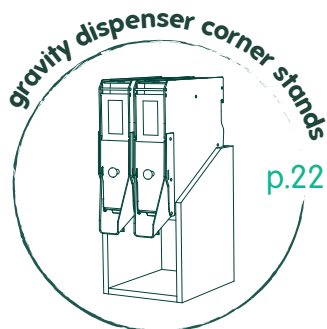
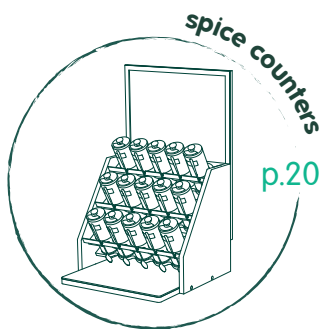

Cabinets | p.27

Some installation examples | p.29

About APPLYMAGE® | p.30

Where and how are the products made?

The products in the APPLYVRAC[®] Eterniti[®] range are **entirely designed and manufactured in France**, in the Lyon region, using the **best conventional machining techniques** and a **short supply chain** and local economy approach.

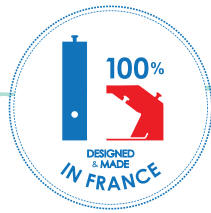

What does it include? wide choice from 2 to 30L

The APPLYVRAC[®] Eterniti[®] range is made up of eco-designed gravity dispensers, scoop dispensers, display cases, specific dispensers, display stands and corner cabinets. It is constantly evolving to adapt to the **changing needs of retailers and convenience shops** (organic and bulk grocery shops, local alternative grocery shops, delicatessens and local producers, etc.).

Which requirements do the products meet?

Food-grade compliance

The materials used to make the products in the APPLYVRAC[®] Eterniti[®] range are naturally **recyclable**. They are approved for contact with food and free from both BPA and phthalates. These physiologically safe **materials** are all **certified according to the standards in force and the latest food regulations** (analyses and tests carried out by several independent French and foreign laboratories).

Hygiene

The **excellent airtightness** of these dispensers, as well as the antimicrobial treatment used for coating the service knobs, **significantly reduce health risks**. Many parts have been designed to be easily removable and disassembled to enable **quick and thorough cleaning**.

Sustainability

The materials selected are of **top quality** and extremely impact-resistant, thus ensuring **durability** and a **long lifespan** of the equipment. The **complete repairability** of APPLYVRAC[®] Eterniti[®] dispensers further extends their lifespan.





clean lines for total transparency

- design combining **simplicity, aesthetics and functionality**
- **excellent product visibility** to **showcase items** in a neat and original way
- **easy to use** for customers
- Instant **visual control** helps shopkeepers to:
 - monitor stocks in real time
 - step up the prevention of health risks



installation efficiency and freedom

- **less space taken up** in aisles
- **wide choice of volumes** (2 to 30 litres) and **models** adapted to the products and their shelf lives
- **installation possible on all kinds of furniture:**
 - numerous installation solutions (from kitchen dressers to custom furniture)
 - several attachment methods available (very handy for mobile grocery vans)
- **setting up a bulk corner:** specific display stands or cabinets ready to install with integrated dispensers (p.22)



control and pleasure of self-service

- **intuitive to use:**
 - flap that opens gradually and bag-holder on gravity dispensers
 - reduced waste thanks to the gravity dispensers' safety lock
 - lid that slides downwards on scoop dispensers
- **perfect stability:**
 - safety during handling
- **easy to fill**
- **optimum balance** between dimensions, weights and volumes:
 - reduction in expenses and prevention of musculo-skeletal disorders



enhanced hygiene

- **easy cleaning** and maintenance:
 - many parts are removable or extractable (including the gravity dispenser spout for regular and rapid cleaning)
 - dispensers are lightweight and sturdy, so they can be cleaned manually with vigour
 - can be placed in professional dishwashers
- **excellent airtightness:**
 - gravity dispensers have a lock and dual-flap system, which helps to reduce health risks
 - scoop dispensers have airtight lids
- **contact area restricted to release knobs** during service:
 - knobs are treated against germs, bacteria, viruses and coronaviruses (including Covid-19)
 - scoop dispensers can be opened without touching the inside of the lid



exceptional durability

- the materials used are of **top quality** and **extremely impact-resistant**
 - they are guaranteed to be sturdy and last an extremely long time
- **extended life span** of the products:
 - total, simple and fast repairability
 - all components can be replaced by the user
 - assembly is fully mechanical with stainless steel crosspieces (no gluing or welding) / no plastic injection-moulded parts
 - reduction in waste as well as logistical and transport constraints (reduced carbon footprint)
- **5-year contractual warranty**



possibility of customisation and tailor-made items

- **in-house design office**
- **adaptation of an existing project** or **a project from A to Z**
 - according to specifications defined with the client

GRAVITY DISPENSERS

What products are they suitable for?

Small, non-powdery, non-sticky, non-liquid, packaging-free products*

** Kinds of products: please refer to the "contents/containers" list provided*

Thanks to their gentle and gradual **DUAL-FLAP** system, APPLYVRAC® Eterniti® gravity dispensers **DISPENSE JUST THE RIGHT AMOUNT** and offer **GREAT VISIBILITY**. The safety lock reduces waste and health risks. The bag-holder makes it easier for customers to fill up their bags. The extractable parts (lid, front panel, flap, spout and bag-holder) ensure **EFFECTIVE CLEANING**. Several attachment methods are available for greater installation efficiency and freedom. This handy solution is particularly popular in mobile grocery vans.

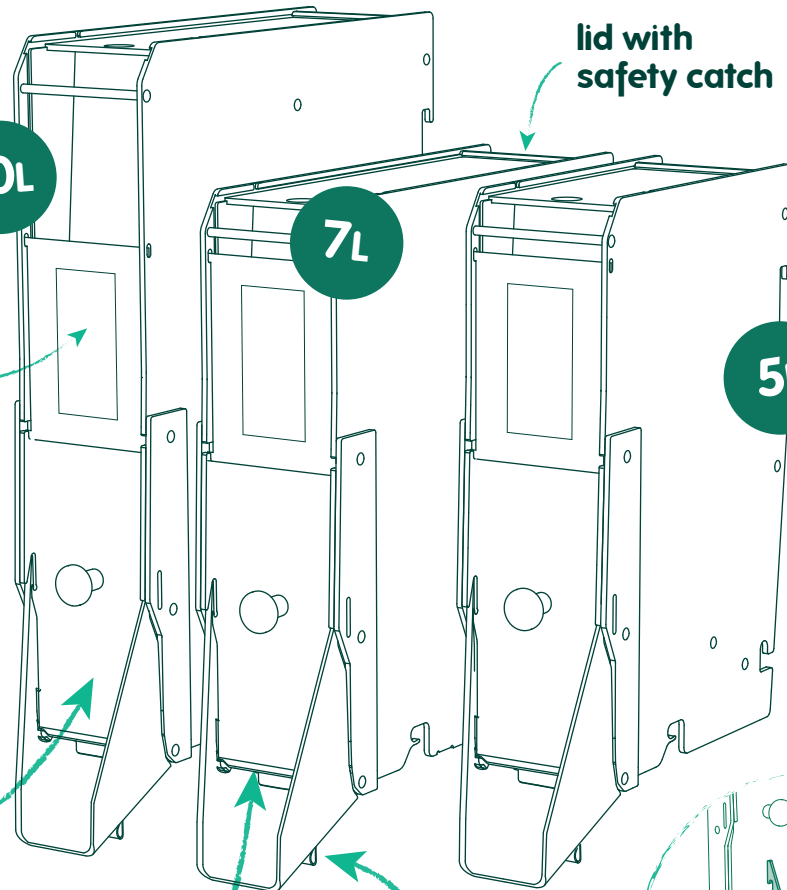

lid with safety catch

10L

7L

5L

transparent and removable large format label holder

gentle and gradual vertical opening

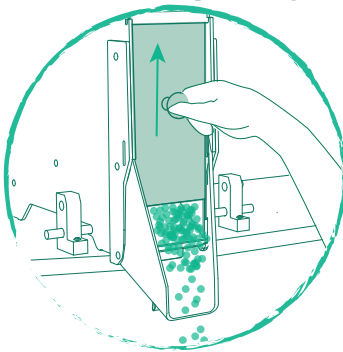

dual flap with safety lock

opening and closing in 2 stages: safer, more hygienic more airtight and no waste!

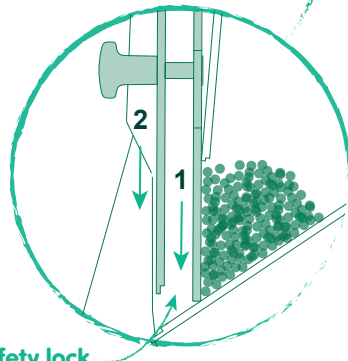

safety lock

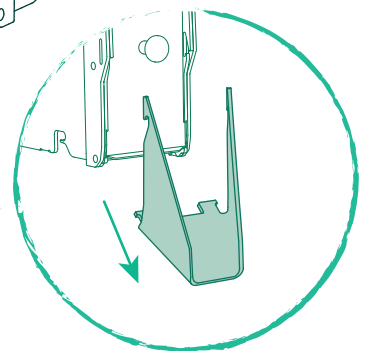

extractable spout

for quick and easy filling and cleaning

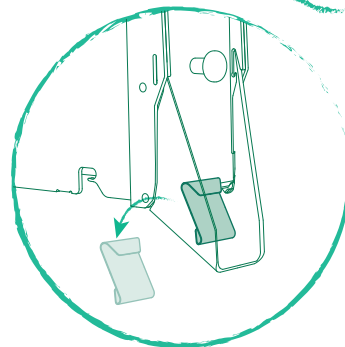

removable bag-holder

makes it very easy for customers to fill up their bags



• Dimensions (in mm)

5L overall: 120 (w.) x 457 (h.) x 300 (d.) ⁽¹⁾
(excl. spout: 120 (w.) x 395 (h.) x 278 (d.))

7L overall: 120 (w.) x 457 (h.) x 400 (d.) ⁽²⁾
(excl. spout: 120 (w.) x 395 (h.) x 378 (d.))

10L overall: 120 (w.) x 552 (h.) x 400 (d.) ⁽²⁾
(excl. spout: 120 (w.) x 490 (h.) x 378 (d.))

⁽¹⁾ : min. depth of the furniture unit or shelf: 219 mm

⁽²⁾ : min. depth of the furniture unit or shelf: 319 mm

• Materials 

Food-grade recyclable PET-G (without Bisphenol A and phthalates), silicone and stainless steel, solid wood (PEFC)

• Weight

5L: approx. 2.1 kg

7L: approx. 2.4 kg

10L: approx. 2.9 kg



Extended life span



Total reparability



Less space taken up in aisles



Knobs treated against germs

SCOOP DISPENSERS

What products are they suitable for?

Products of all sizes, including powdery and floury, complex-shaped and non-liquid products.

The extremely **AIRTIGHT** and **INCREDIBLY VERSATILE** APPLYVRAC® Eterniti® scoop dispensers can be used for all kinds of food or non-food products. Their extractable scoop holder, top hatch and lid make them **EASY TO FILL** and **CLEAN**.

Thanks to its optimum "space-to-volume" ratio and its wide opening, 20L and 30L dispensers are ideal for **VERY HIGH TURNOVER PRODUCTS** (pasta, sugar, flour, sodium bicarbonate, animal food, etc.)

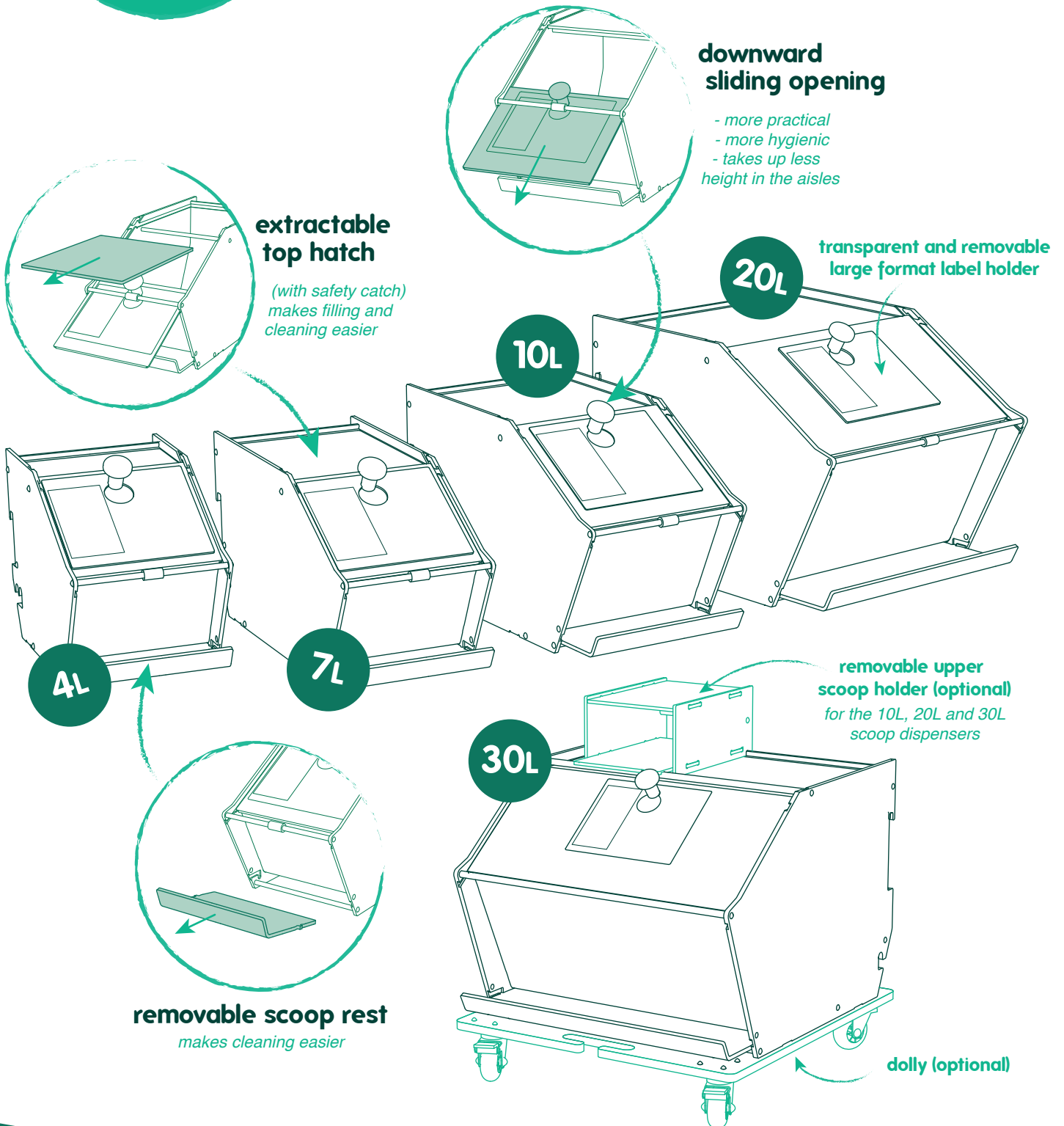

completely transparent for excellent product visibility and promotion



downward sliding opening:
more practical, more hygienic

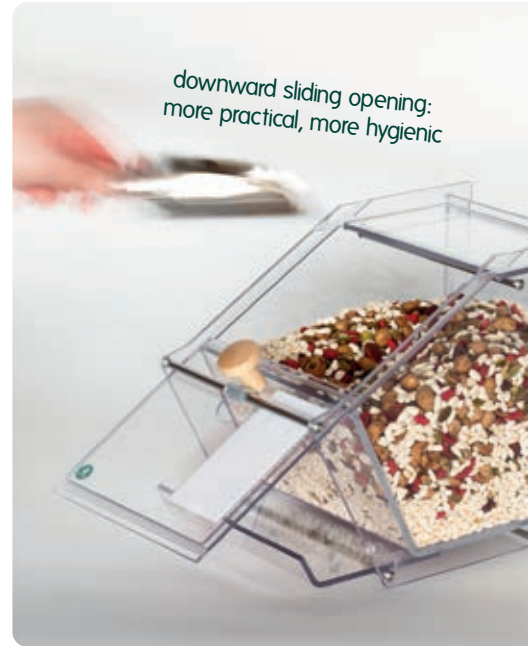

dolly tailored to the 30L model (optional)



very easy to clean



• Dimensions (in mm)

- 4L: 170 (w.) x 217 (h.) x 270 (d.)
- 7L: 170 (w.) x 217 (h.) x 375 (d.)
- 10L: 200 (w.) x 250 (h.) x 385 (d.)
- 20L: 316 (w.) x 293 (h.) x 400 (d.)
- 30L: 392 (w.) x 315 (h.) x 415 (d.)

• Materials 

Food-grade recyclable PET-G (without Bisphenol A and phthalates), silicone and stainless steel, solid wood (PEFC)

• Weight

- 4L: approx. 1.2 kg
- 7L: approx. 1.6 kg
- 10L: approx. 2 kg
- 20L: approx. 3.6 kg
- 30L: approx. 5.4 kg
(dolly: approx. 2.1 kg)



Extended life span



Total reparability



Optimum airtightness



Knobs treated against germs

2L DIY* SMALL SCOOP DISPENSER

* do it yourself

What products are they suitable for?

Ideal for **loss leaders** or **products to be tested for sale**

The 2L APPLYVRAC® Eterniti® scoop dispenser is particularly suitable for displaying and housing **LOSS LEADERS**, **'TOP PICKS'**, products **TO BE TESTED FOR SALE**, or **FESTIVE/SEASONAL PRODUCTS**. Its **COMPACT SIZE** and **LOW PRICE** make it ideal for mass installation in order to group product families together and encourage free placement in the sales space. It is also more **ECO-FRIENDLY** thanks to its flat packaging, which significantly

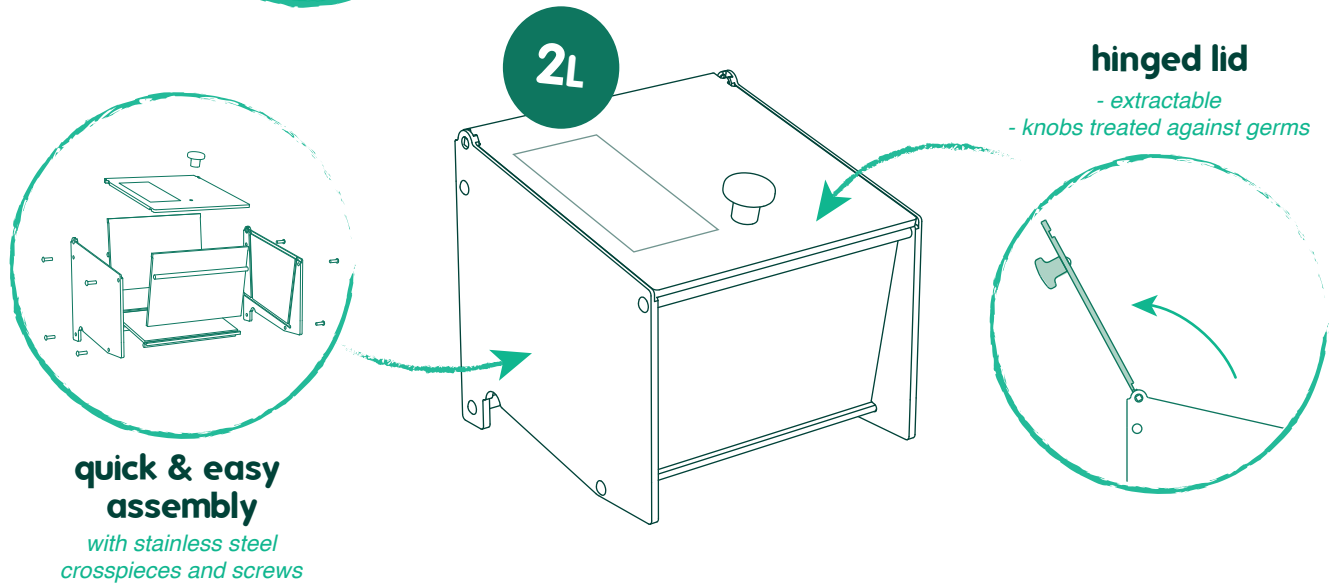

can be stacked on 2 or 3 levels, if required



• **Dimensions** (in mm)
170 (w.) x 157 (h.) x 160 (d.)

• **Materials** Food-grade recyclable PET-G (without Bisphenol A and phthalates) and stainless steel, solid wood (PEFC)

• **Weight**
approx. 0.7 kg



Extended life span



Total reparability



Lightweight



Ideal for festive periods



Knobs treated against germs

SMALL DISPLAY CASE

What products are they suitable for?

ideal for top picks!

The very elegant 3L APPLYVRAC® Eterniti® display case is ideal for presenting and housing **LOSS LEADERS**, **'TOP PICKS'** or **VALUABLE PRODUCTS**. As it **DOES NOT TAKE UP MUCH SPACE**, it can be placed anywhere, including in prime positions in sales areas. With its removable lid, front panel and scoop rest, it is quick and easy to look after.

rapid and simple maintenance

thanks to removable lid, front panel and scoop rest

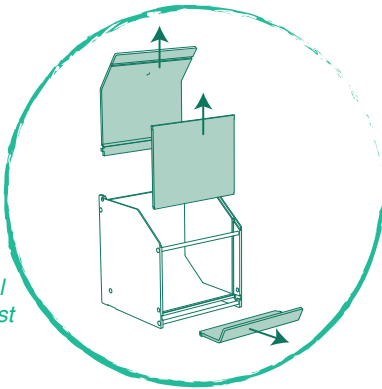

3L

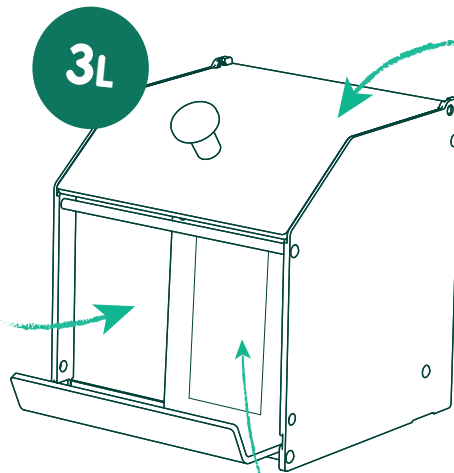

transparent and removable label holder

hinged lid

- very large opening
- extractable
- optimum airtightness
- knobs treated against germs

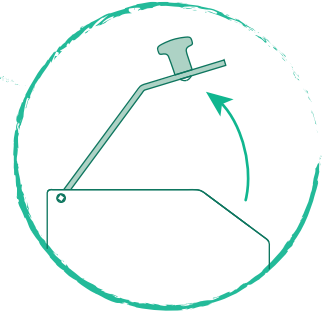

optimum accessibility



very easy to clean

• Dimensions (in mm)
170 (w.) x 196 (h.) x 215 (d.)

• Materials 
Food-grade recyclable PET-G (without Bisphenol A and phthalates), silicone and stainless steel, solid wood (PEFC)

• Weight
approx. 0.9 kg



Extended life span



Total reparability



Lightweight



Ideal for festive periods



Knobs treated against germs

LARGE DISPLAY CASES

WITH LID

Due to their natural elegance, the APPLYVRAC® Eterniti® large display cases can be used for products which require **SPECIAL PRESENTATION** and can't be placed in gravity or scoop dispensers (chocolate bars, cosmetics or hygiene products, etc.) and/or **LOSS LEADERS** or valuable items.

Their removable tongs rest and lid make them particularly **EASY to USE** and **MAINTAIN**.

What products are they suitable for?

Non-crumbly, non-powdery and residue-free products

CLASSIC MODEL WITHOUT PODIUMS

15L

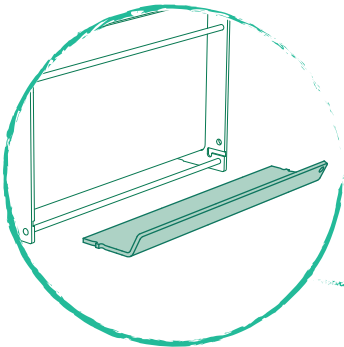

removable tongs rest
makes cleaning easier

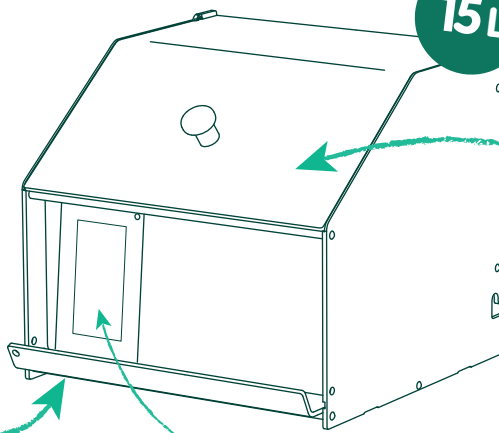

transparent and removable label holder
(additional copies on request)

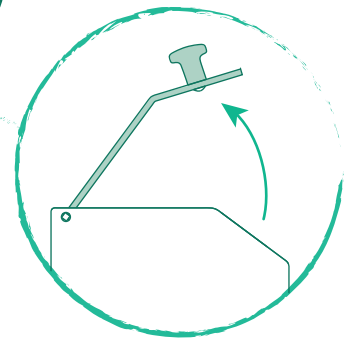

hinged lid
*- very large opening
- extractable*

What products are they suitable for?

Ideal for chocolate bars or cosmetics!

MODEL A WITH PODIUMS AND COMPARTMENTS

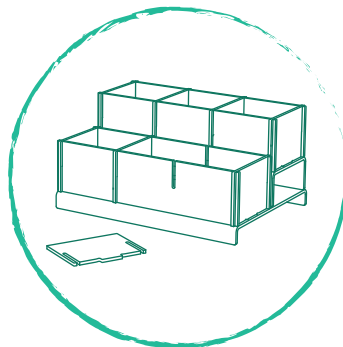

modular podiums
*- 2 to 6 compartments
- removable and fully detachable*

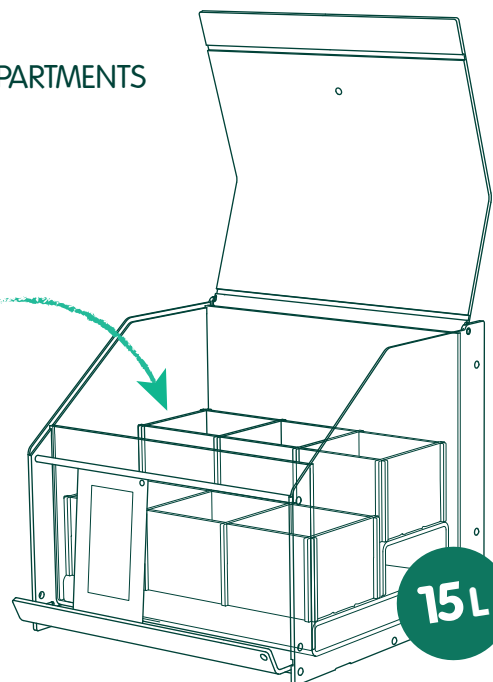

15L

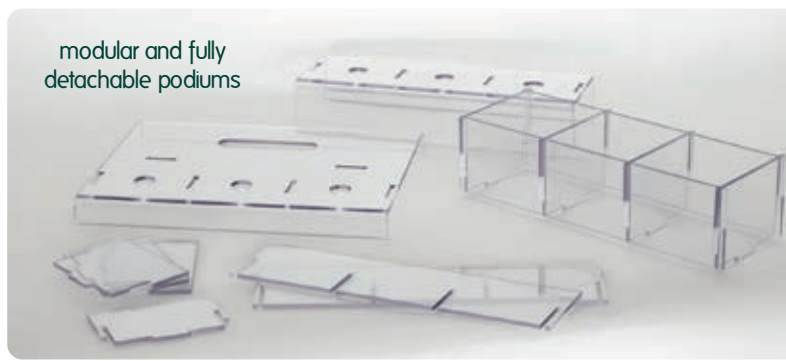

• Dimensions (in mm)

overall: 312 (w.) x 281 (h.) x 327 (d.)
compartments (inside): 90 (w.) x 75 (h.) x 89 (d.)

• Materials

Food-grade recyclable PET-G (without Bisphenol A and phthalates), stainless steel, solid wood (PEFC)

• Capacity

classic model: 15L
model A:
- 36 to 60 chocolate bars (depending on thickness)
- cosmetics, hygiene or other products:
variable depending on the products displayed

• Weight

classic model: approx. 2.6 kg
model A: approx. 3.9 kg



Extended life span



Total reparability



Great modularity



Knobs treated against germs

LARGE DISPLAY CASES

WITHOUT LID

The APPLYVRAC® Eterniti® display cases without lid are **WIDELY ACCESSIBLE** and can therefore display products with very specific and very different shapes that can't be placed in conventional dispensers or containers.

What products are they suitable for?

Non-crumbly, non-powdery and residue-free products

CLASSIC MODEL WITHOUT PODIUMS

13L

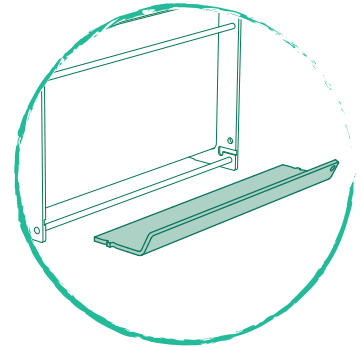
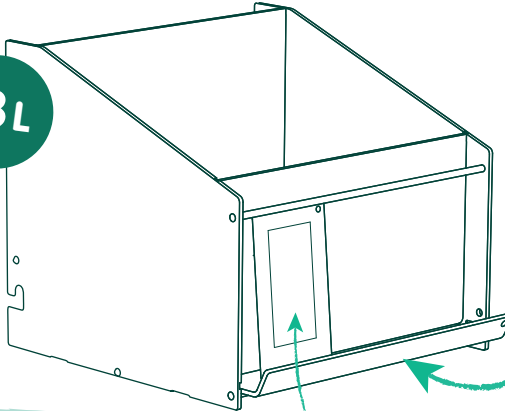

removable tongue rest

makes cleaning easier

transparent and removable label holder
(additional copies on request)

What products are they suitable for?

Ideal for long pasta!

MODEL C WITH PODIUMS AND LARGE BOTTLES

pre-dosing of bottles

250 g of long pasta per 400 ml bottle
500 g of long pasta per 880 ml bottle

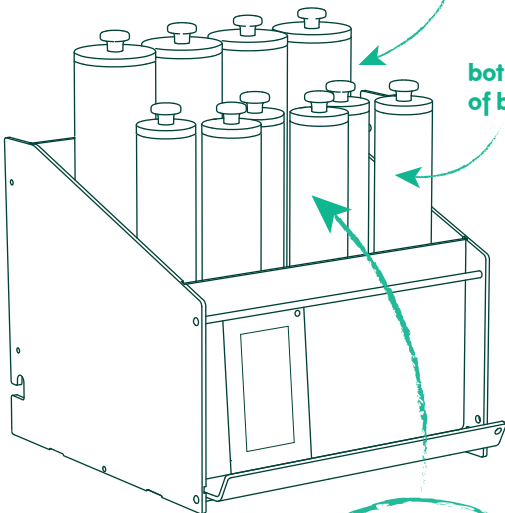

bottles made of borosilicate glass

What products are they suitable for?

Ideal for spices!

better space to number of references ratio

MODEL D WITH PODIUMS AND SMALL BOTTLES

bottles made of borosilicate glass

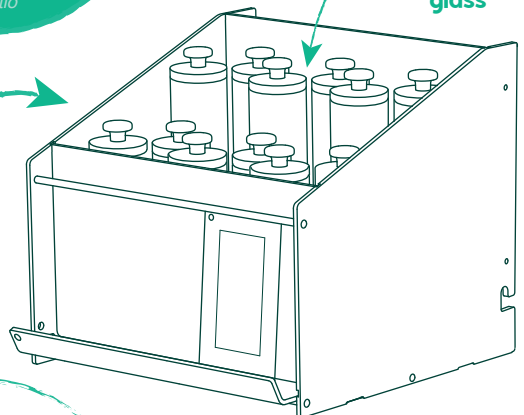

modular bottles and podiums

- excellent airtightness
- easy and quick to clean

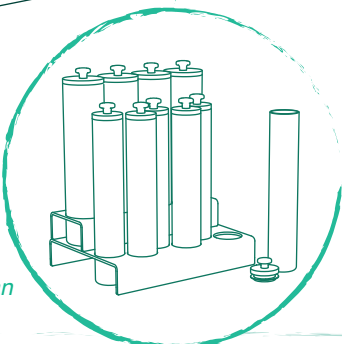

modular bottles and podiums

- excellent airtightness
- easy and quick to clean

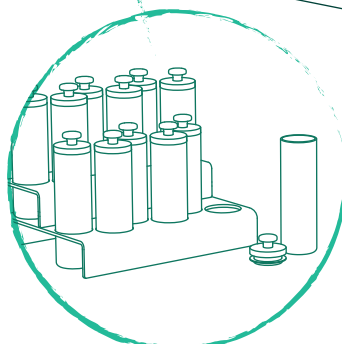

3 possible configurations

- 12 x 230 ml bottles
- 4 x 500 ml bottles + 6 x 230 ml bottles
- 8 x 500 ml bottles



• Dimensions (in mm)

classic model: 312 (w.) x 275 (h.) x 327 (d.)

model C: 312 (w.) x 378 (h.) x 327 (d.)

model D: 312 (w.) x 275 (h.) x 327 (d.)

• Materials

Food-grade recyclable PET-G (without Bisphenol A and phthalates), borosilicate glass, silicone, stainless steel, solid wood (PEFC)

• Capacity

model C: 4 x 880 ml bottles + 6 x 400 ml bottles

model D (3 possible configurations):

- 12 x 230 ml bottles
- 4 x 500 ml bottles + 6 x 230 ml bottles
- 8 x 500 ml bottles

• Weight

classic model: approx. 2.2 kg

model C: approx. 5.8 kg

model D: approx. 4.6 kg



Extended life span



Total reparability



Perfectly airtight bottles



Knobs treated against germs

OIL & LIQUID DISPENSERS

What products are they suitable for?

Ideal for vegetable oils!

APPLYVRAC® Eterniti® oil and liquid dispensers are designed to ensure **CLEAN AND SAFE SERVICE** thanks to their precision tap and their removable tray.

The **EMPTYING SYSTEM** ensures that every last drop of the liquid is recovered; it also makes the dispenser easier to clean.

And as these dispensers are totally transparent they are ideal for promoting the product on sale.

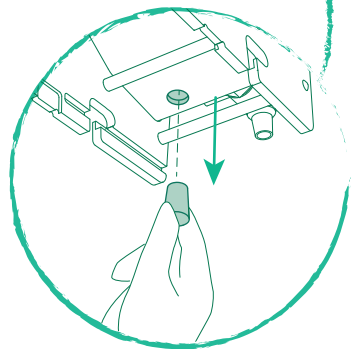
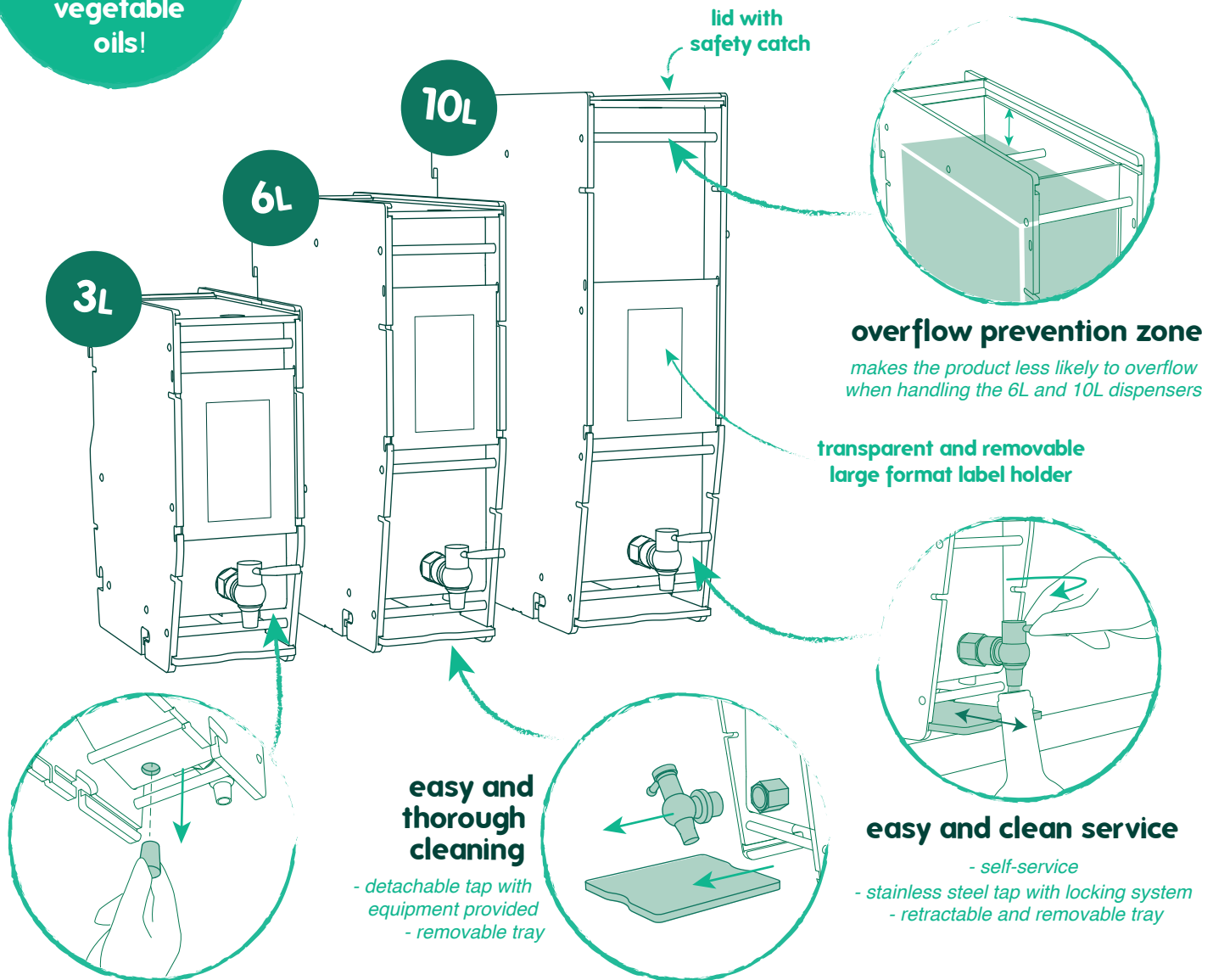

emptying system

- ensures that every last drop is recovered (no loss or waste)
- makes cleaning easier

easy and thorough cleaning

- detachable tap with equipment provided
- removable tray

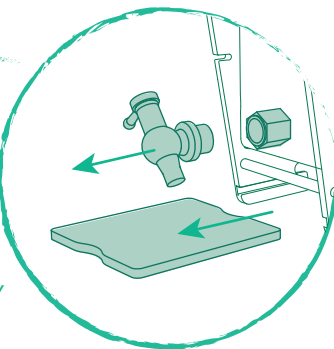

easy and clean service

- self-service
- stainless steel tap with locking system
- retractable and removable tray

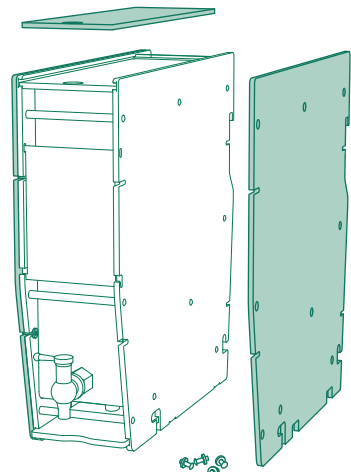
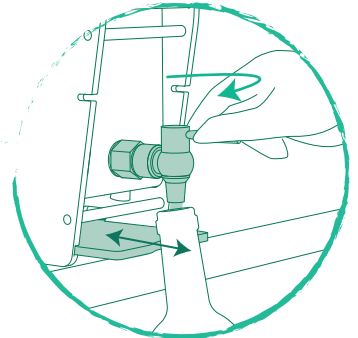

ACCESSORIES

OPACIFYING PLATES (optional)

2 removable plywood side plates and 1 removable plywood top plate: to further protect oil against UV rays

choice between 3 volumes
(3L, 6L and 10L)



very easy to clean



great product promotion



easy and clean
service

with opacifying plates
(optional)



• Dimensions (in mm)

- model 3L: 116 (w.) x 310 (h.) x 310 (d.)¹
- model 6L: 116 (w.) x 395 (h.) x 388 (d.)²
- model 10L: 144 (w.) x 490 (h.) x 388 (d.)²

¹: min. depth of the furniture unit or shelf: 244 mm
²: min. depth of the furniture unit or shelf: 319 mm

• Materials 

Food-grade recyclable PET-G (without Bisphenol A and phthalates), silicone and stainless steel, solid wood (PEFC)

Opacifying plates : plywood

• Weight

- model 3L: approx. 2.3 kg
- model 6L: approx. 3.3 kg
- model 10L: approx. 4.3 kg



Extended life span



Total reparability



No leftover residue



Easy to clean

HONEY DISPENSER

What products are they suitable for?

Ideal for **liquid honey**

such as: acacia, alder buckthorn, chestnut, oak, summer flowers, forest, alfafa, mountain, orange blossom, blackberry, fir and lime blossom, etc.

The APPLYVRAC® Eterniti® honey dispenser is designed to ensure **CLEAN AND SAFE SERVICE** thanks to their precision tap (patented) and their removable pot-holder. The **EMPTYING SYSTEM** ensures that every last drop of the liquid is recovered; it also makes the dispenser easier to clean.

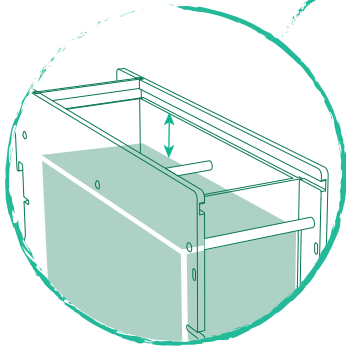

overflow prevention zone

makes the product less likely to overflow when handling the dispenser

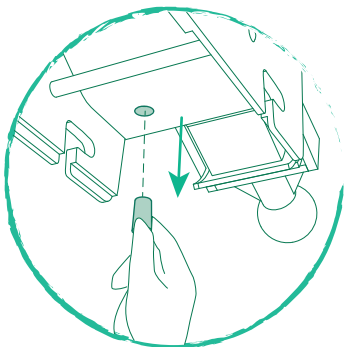

emptying system

- ensures that every last drop is recovered (no loss or waste)
- makes cleaning easier

6L

lid with safety catch

transparent and removable large format label holder

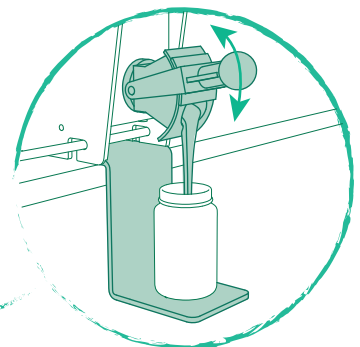

easy and clean service

- self-service
- non-drip honey tap with adjustable flow (patented)
- pot-rest tray

easy and thorough cleaning

- detachable tap with equipment provided
- removable pot rest

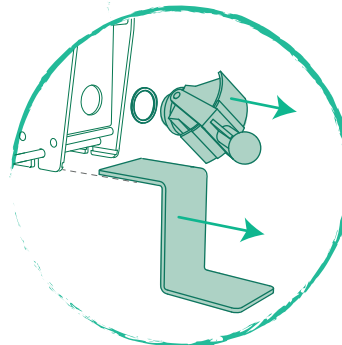



• Dimensions (in mm)

- without tray: 116 (w.) x 395 (h.) x 478 (d.)*
- with tray: 116 (w.) x 550 (h.) x 478 (d.)*

*: min. depth of the furniture unit or shelf: 319 mm

• Materials 

Food-grade recyclable PET-G (without Bisphenol A and phthalates), stainless steel, polyamide and silicone

• Weight

approx. 3.3 kg



Extended life span



Total reparability



No leftover residue



Easy to clean

ATTACHMENT KIT

unique attachment* system for all APPLYVRAC® Eterniti® dispensers

• **Material**

PEFC plywood

set square

- defines the position of the L brackets
- ensures quick, easy and safe installation

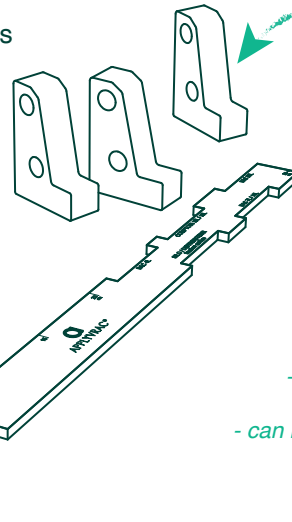
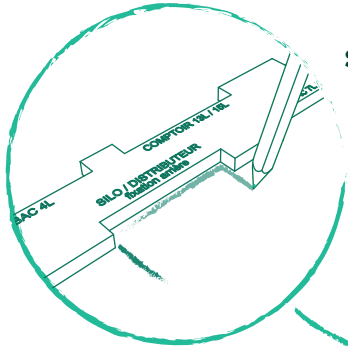

L brackets

- for threading and holding the retention bar (not provided)
- can be placed beside or below the distributors to be attached

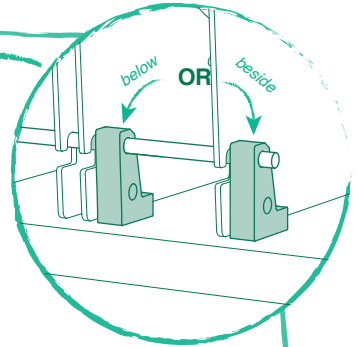

*: Bar attachment with brackets is mandatory for gravity dispensers and specific dispensers, and optional for scoop dispensers and display cases in fixed grocery shops.

FILLING FUNNEL

Identical model for all APPLYVRAC® Eterniti® gravity dispensers

• **Material**

Food-grade recyclable PET-G (without Bisphenol A)

practical

- for fast, safe and clean filling

detachable

- takes up less space (delivered flat)
- easy and quick to clean

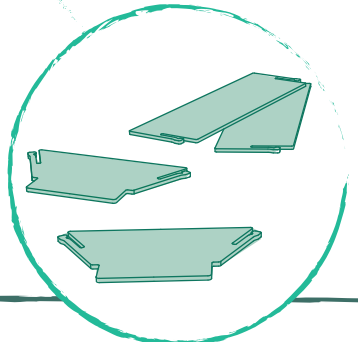
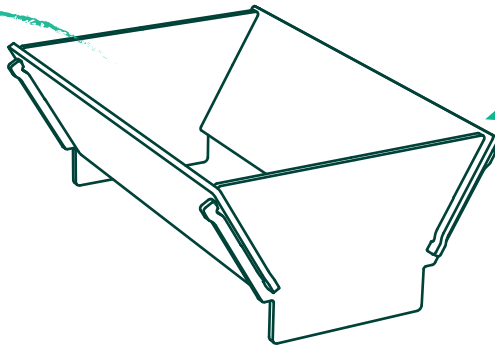
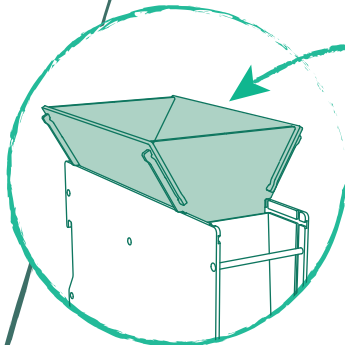

SERVING FUNNEL

Adapted to customers' small containers

• **Material**

Food-grade recyclable HDPE (without Bisphenol A)

holes for threading a strap (safe use)

slot for attachment to the gravity dispenser's bag-holder

practical

- for self service (can be attached to the gravity dispenser's bag-holder)
- identical model for all Applyvrac® gravity dispensers

can be rolled-up/unrolled

- takes up less space (delivered flat)
- quick and easy to clean

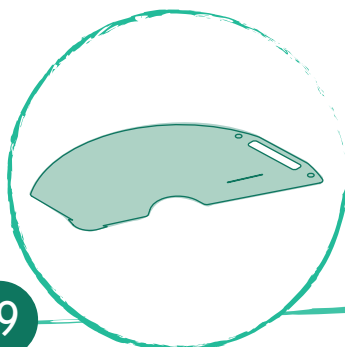
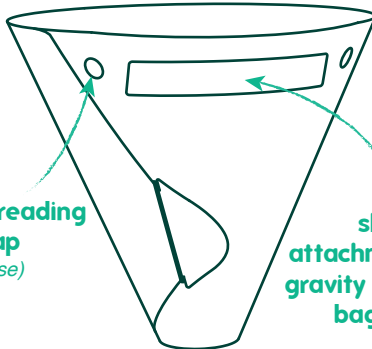
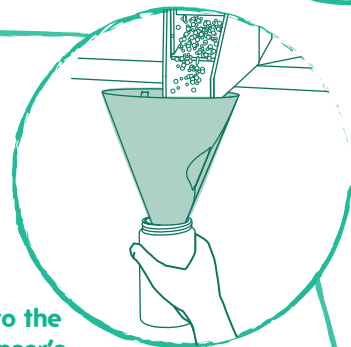

NEW
SPICE COUNTERS

This display stand has been specially designed to offer **THE LARGEST SELECTION OF HERBS AND SPICES** for sale in a **COMPACT SPACE**. **MODULAR** and requiring no special installation, it will always find its place in any retail environment.

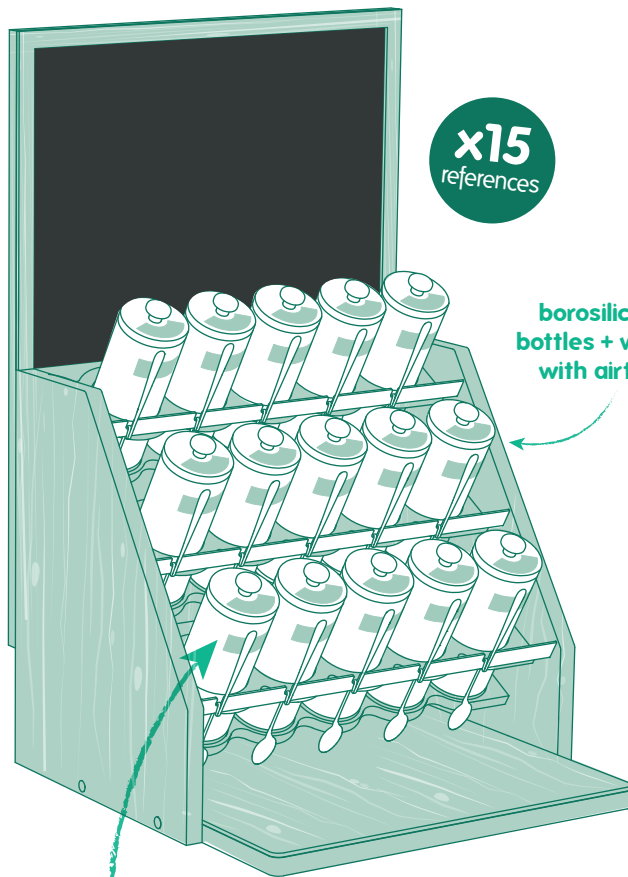

x15
references

borosilicate glass
bottles + wooden lids
with airtight seals

removable
blackboard-style
rear panel
(optional)

solid wood structure

x10
references

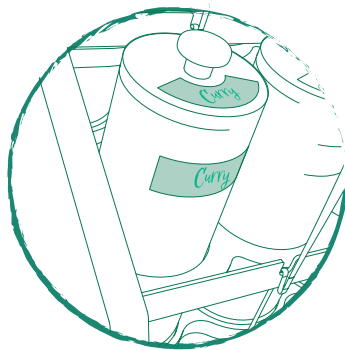
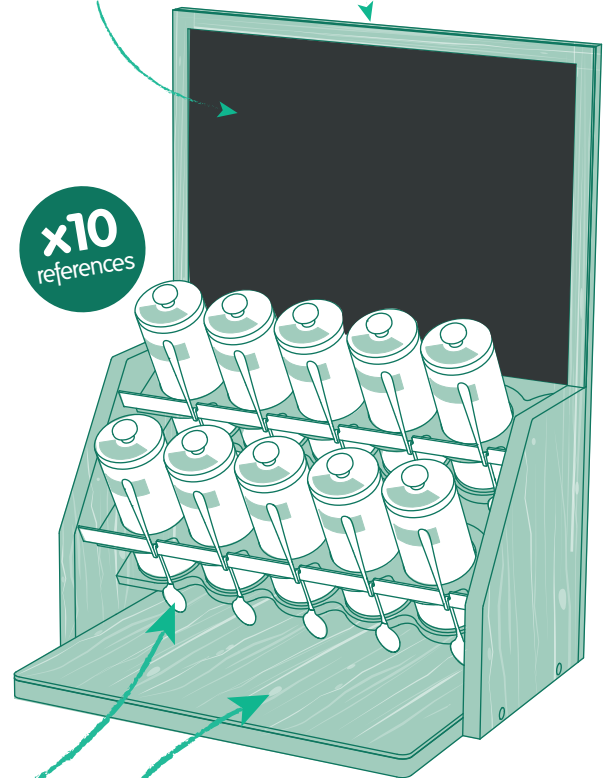

double labelling

- reduces the risk of mixing references
- guarantees excellent visibility for customers
- blank, erasable labels provided

spoon service

- stainless steel spoons integrated into the display stand
- 1 spoon per bottle
- precise service in small quantities

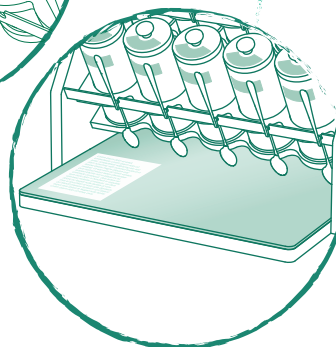
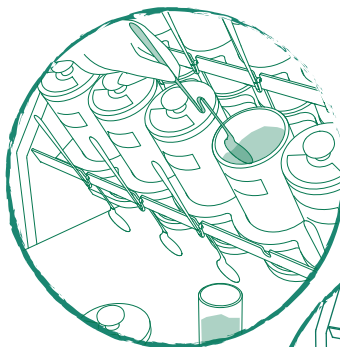

**transparent, removable
service plate**

- quick and easy to clean on a daily basis
- possibility to slide detailed information sheets underneath
- protection for the wooden base

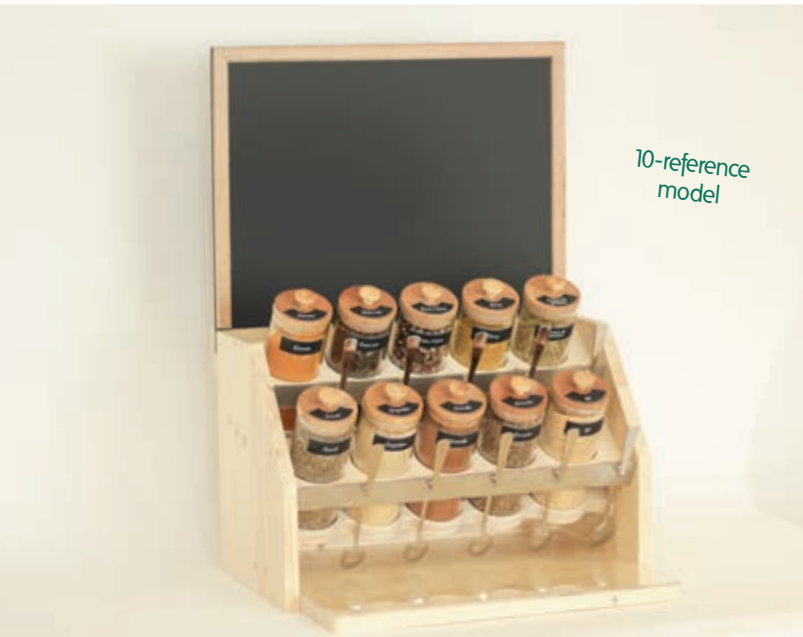

• Dimensions (in mm)

10-reference model: 460 (w.) x 362 (h.) x 380 (d.)
with rear panel: 460 (w.) x 635 (h.) x 415 (d.)
15-reference model: 460 (w.) x 467 (h.) x 460 (d.)
with rear panel: 460 (w.) x 750 (h.) x 495 (d.)

• Capacity

500 ml / bottle

• Materials 

structure: solid pine wood, plywood (PEFC- and/or FSC-certified), food-safe varnish, PMMA
bottle: food-grade borosilicate glass, solid wood (PEFC), silicone and stainless steel
spoon: food-grade stainless steel



Extended life span



Total reparability



Perfectly airtight bottles



Knobs treated against germs

GRAVITY DISPENSER CORNER STANDS

ideal for setting up a bulk corner
with small, non-powdery,
non-sticky, non-liquid,
packaging-free products

For more information about gravity dispensers, please refer to p. 5.

These display stands have been designed for APPLYVRAC® Eterniti® 5L, 7L and 10L gravity dispensers and 3L and 6L liquid dispensers. These **LIGHTWEIGHT** and **MODULAR** stands are particularly suitable for **SETTING UP A SMALL BULK CORNER** in a retail store, a cultural space, a shared space (coliving, coworking spaces, etc.) or for showcasing new products during commercial events (trade shows, fairs, etc.).

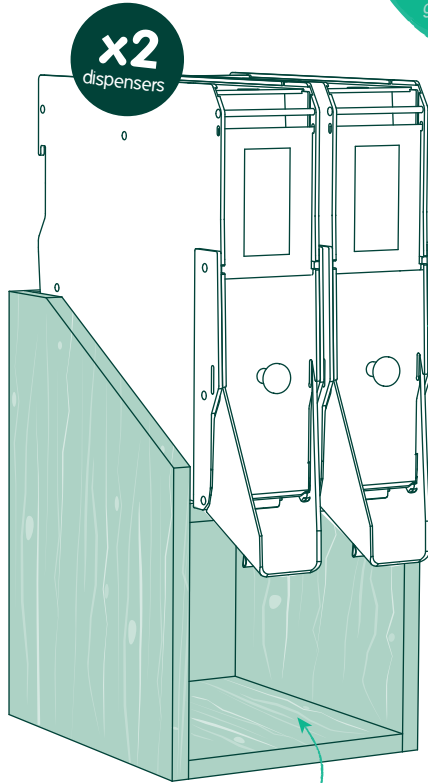

x2
dispensers

free space for bags or containers

integrated mounting bar

- secure dispensers
- perfect stability during service
- no installation required

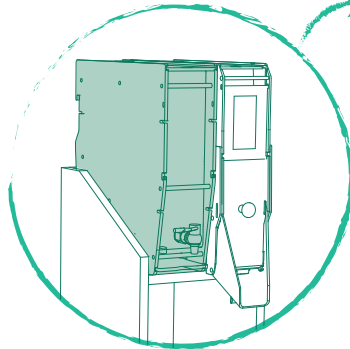

x4
dispensers

compatible with several models

- 5L, 7L and 10L-gravity dispensers
- 3L and 6L-oil and liquid dispensers

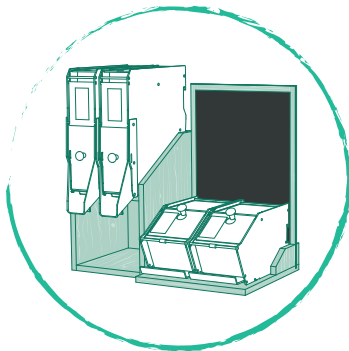

can be combined with scoop dispenser corner stands

to be displayed together or separately

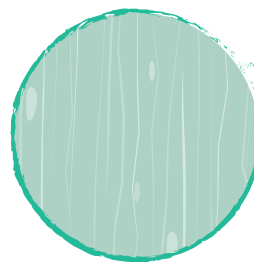

solid wood

- made of PEFC- and/or FSC-certified pine
- made in France
- food-safe varnish

ACCESSORIES

UTENSILS BOX

made of solid wood with 2 compartments:
ideal for storing various utensils, napkins, etc.

Dimensions (In mm):
170 (w.) x 230 (d.) x 100 (h.)

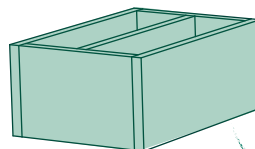

to be placed freely in the lower free space or next to the corner stand

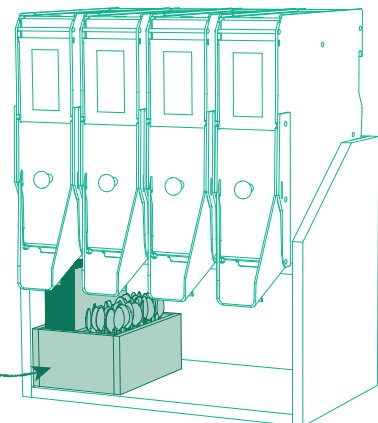

x2 dispensers model



x4 dispensers model



compatible with
several dispensers



can be combined
with scoop dispenser
corner stands



Dimensions (in mm)

x2 dispensers model:

- without gravity dispensers:
281 (w.) x 334 (d.) x 440 (h.)
- with 5L/7L gravity dispensers:
281 (w.) x 416 (d.) x 660 (h.)
- with 10L gravity dispensers:
281 (w.) x 416 (d.) x 755 (h.)

x4 dispensers model:

- without gravity dispensers:
526 (w.) x 334 (d.) x 440 (h.)
- with 5L/7L gravity dispensers:
526 (w.) x 416 (d.) x 660 (h.)
- with 10L gravity dispensers:
526 (w.) x 416 (d.) x 755 (h.)

Materials

solid pine wood (PEFC-
and/or FSC-certified)
food-safe varnish



Extended life span



Less space
taken up in aisles



Dispensers are
easy to clean



Knobs treated
against germs

SCOOP DISPENSER CORNER STANDS

ideal for setting up a bulk corner
with products of all sizes, including powdery and floury, complex-shaped and non-liquid products.

For more information about scoop dispensers, please refer to p. 7.

x2
bacs

removable blackboard-style rear panel (optional)

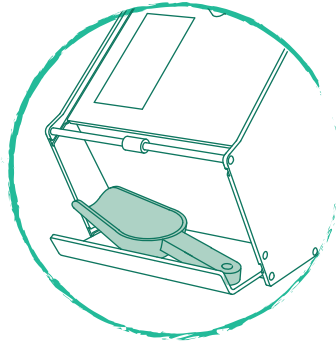
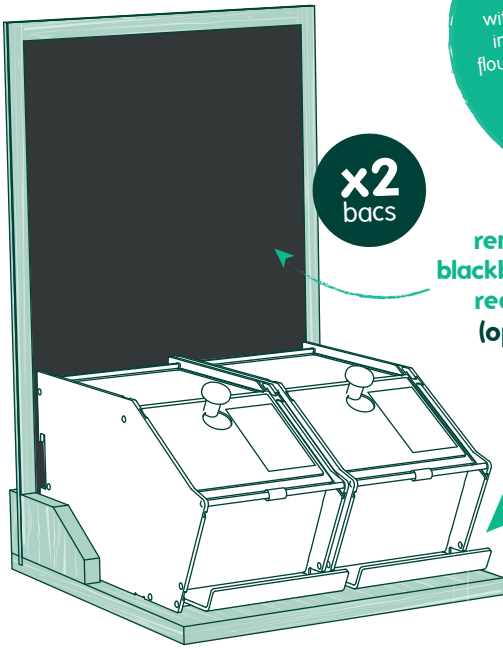

integrated scoop rest
removable and extractable

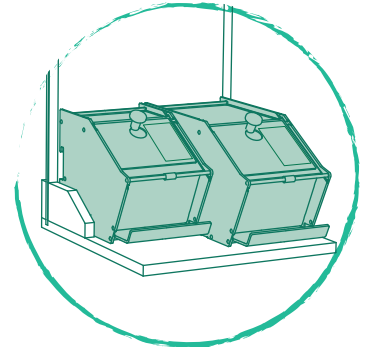

compatible with 4L and 7L scoop dispensers

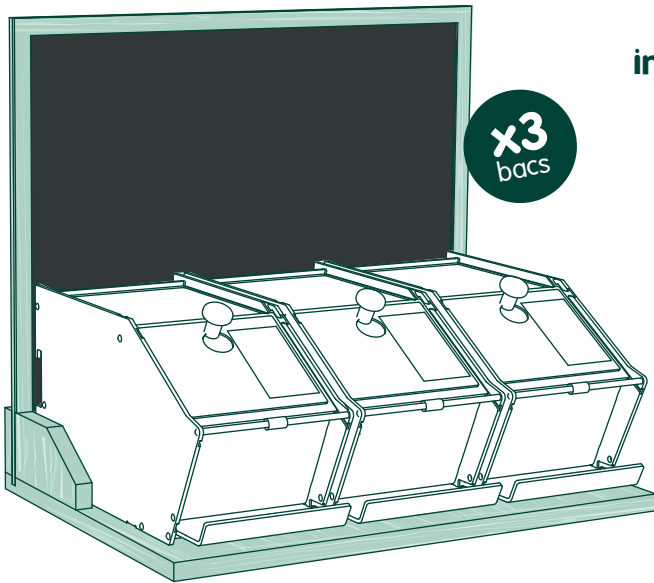

x3
bacs

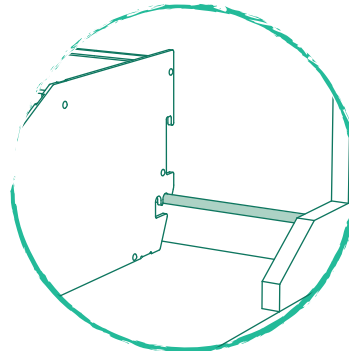

integrated mounting bar

- secure dispensers
- perfect stability during service
- no installation required

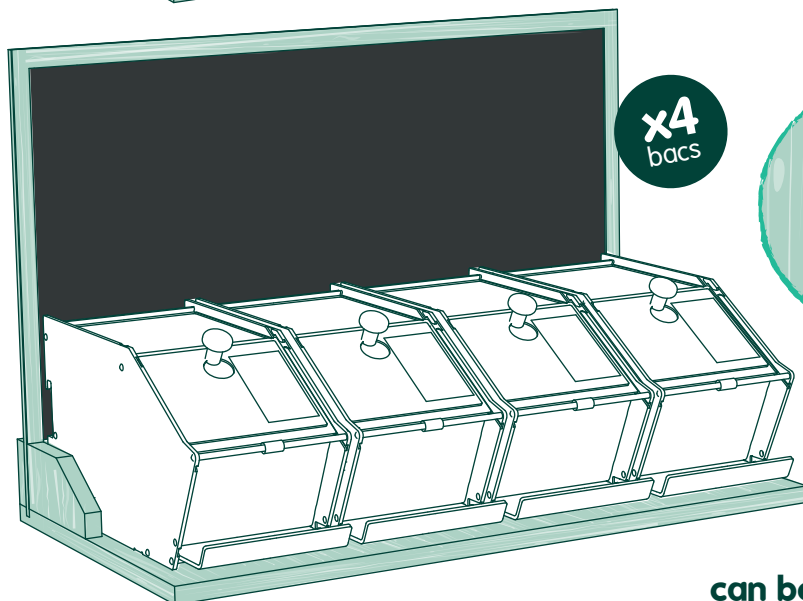

x4
bacs



solid wood

- made of PEFC- and/or FSC-certified pine
- made in France
- food-safe varnish

can be combined with gravity dispenser corner stands

to be displayed together or separately

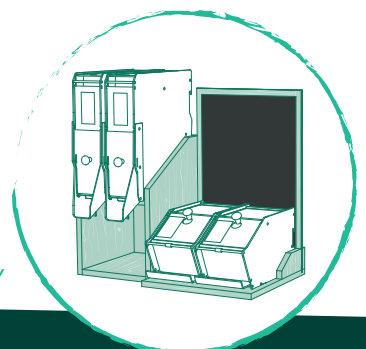



x2 scoop dispensers
model (4L / 7L)



x3 scoop dispensers model (4L / 7L)



removable
blackboard-style
rear panel
(optional)



x4 scoop dispensers model (4L / 7L)



can be combined
with gravity dispenser
corner stands



integrated
mounting bar

• Dimensions (in mm)

x2 scoop dispensers model:

- without scoop dispensers:
381 (w.) x 390 (d.) x 600 (h.)
- with 4L scoop dispensers:
381 (w.) x 390 (d.) x 600 (h.)
- with 7L scoop dispensers:
381 (w.) x 402 (d.) x 600 (h.)

x3 scoop dispensers model:

- without scoop dispensers:
560 (w.) x 390 (d.) x 500 (h.)
- with 4L scoop dispensers:
560 (w.) x 390 (d.) x 500 (h.)
- with 7L scoop dispensers:
560 (w.) x 402 (d.) x 500 (h.)

x4 scoop dispensers model:

- without scoop dispensers:
735 (w.) x 390 (d.) x 500 (h.)
- with 4L scoop dispensers:
735 (w.) x 390 (d.) x 500 (h.)
- with 7L scoop dispensers:
735 (w.) x 402 (d.) x 500 (h.)

• Materials

- solid pine wood (PEFC-
and/or FSC-certified)
- food-safe varnish

height without blackboard (with dispensers): 222 mm



Extended life span



Less space
taken up in aisles



Dispensers are
easy to clean



Knobs treated
against germs

PODIUM

to place above the scoop dispenser corner stands

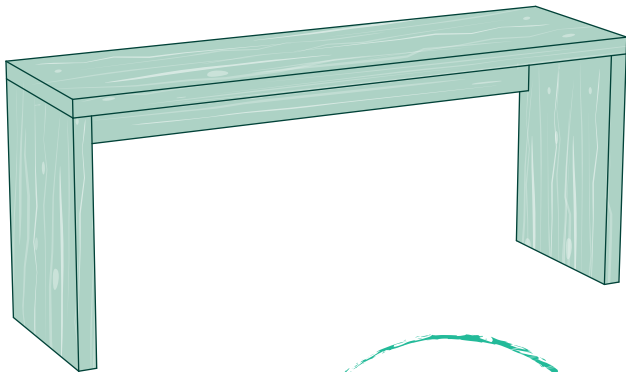

- **Materials**
solid pine wood (PEFC- and/or FSC-certified)
food-safe varnish
- **Dimensions** (in mm)
 - podium 60 cm: 601 (w.) x 175 (d.) x 260 (h.)
 - podium 78 cm: 776 (w.) x 175 (d.) x 260 (h.)

practical

ideal for storing various items: bags, containers, utensil box, etc.

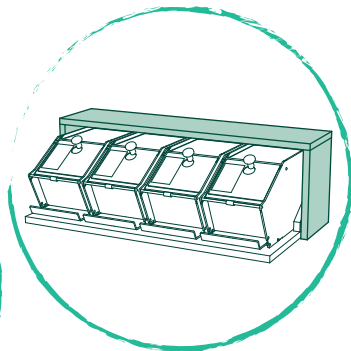
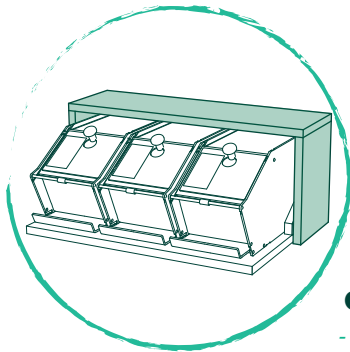

available in 2 formats

- width 60 cm: to place above the x2 or x3 scoop dispenser models
- width 78 cm: to place above the x3 or x4 scoop dispenser models



UTENSILS BOX

made of solid wood with 2 compartments

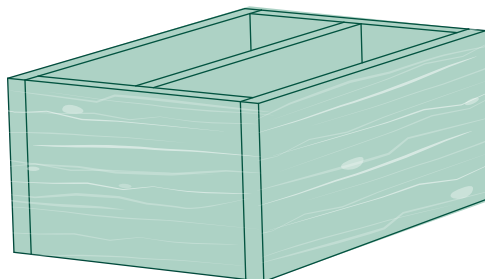

- **Materials**
solid pine wood (PEFC- and/or FSC-certified)
food-safe varnish
- **Dimensions** (in mm)
170 (w.) x 230 (d.) x 100 (h.)



very universal

- *ideal for storing various utensils, napkins, bags, etc.*
- *to be placed freely next to or on the corner stand, on the podium, etc.*

better
space to number
of references
ratio

This cabinet is designed for use with APPLYVRAC® Eterniti® 5L and/or 7L gravity dispensers and 4L and/or 7L scoop dispensers.
With its **CUSTOMISABLE** and **REMOVABLE SIGN**, it is particularly suitable for **SETTING UP A BULK AREA** in a retail store, concept store, cultural space, shared space (coliving, coworking space, etc.) or for showcasing products from a specific supplier.



**customisable
and removable sign**
more installation freedom

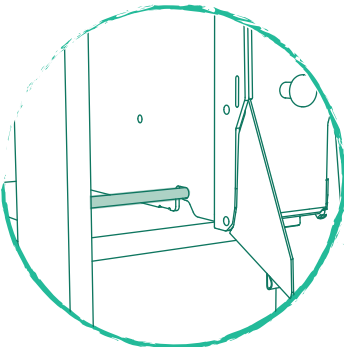

integrated mounting bar
*- secure dispensers
- perfect stability during service*

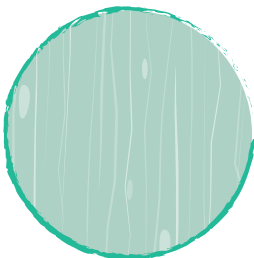

solid wood
*- made of PEFC- and/or FSC-certified pine
- made in France
- food-safe varnish*



**several possible
configurations:**

- 2 rows of gravity dispensers / 1 row of scoop dispensers
- 1 row of gravity dispensers / 2 rows of scoop dispensers
- 1 row of gravity dispensers / 1 row of scoop dispensers

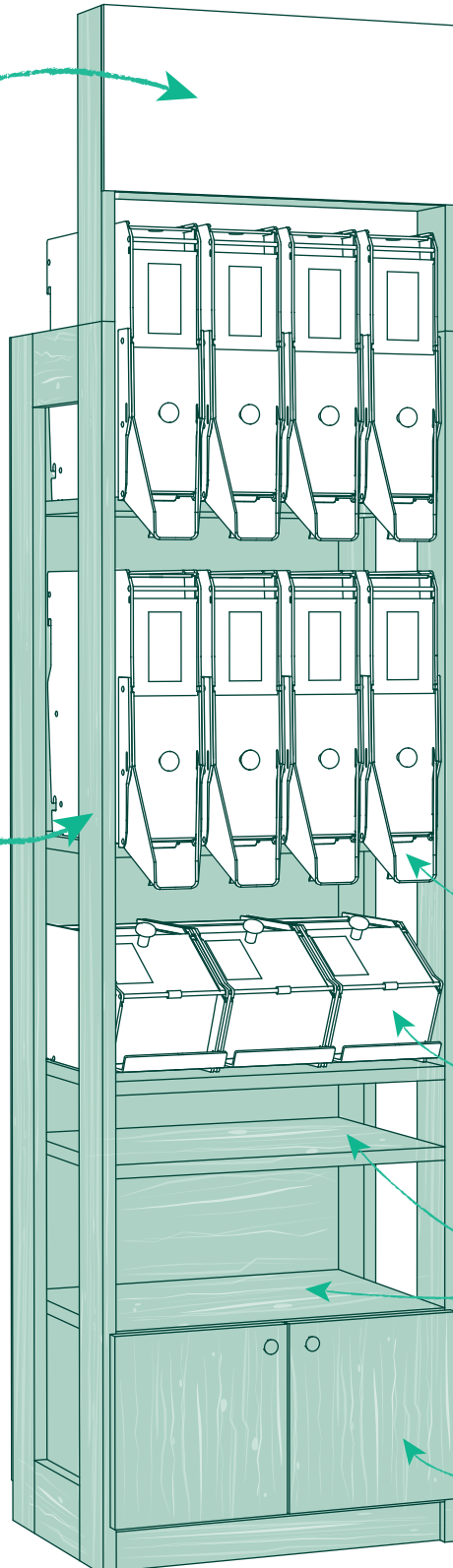

1 or 2 rows of
4 x 5L and/or 7L
gravity dispensers

1 or 2 rows of
3 x 4L and/or 7L
scoop dispensers

free space for bags,
containers or
pre-packaged products

storage cupboard



● **Dimensions** (in mm, with dispensers)

560 (w.) x 2250 (h.) x 450 (d.)
without sign: 560 (w.) x 1950 (h.) x 450 (d.)

● **Capacity**

depending on the configuration:

- 8 x 5L and/or 7L gravity disp. and 3 x 4L and/or 7L scoop disp.
- 4 x 5L and/or 7L gravity disp. and 6 x 4L and/or 7L scoop disp.
- 4 x 5L and/or 7L gravity disp. and 3 x 4L and/or 7L scoop disp.

● **Materials**

solid pine wood (PEFC-
and/or FSC-certified)
food-safe varnish



Extended life span



Less space
taken up in aisles



Dispensers are
easy to clean



Knobs treated
against germs

Some installation examples of the APPLYVRAC® range eterniti



about



Our expertise

APPLYMAGE® , based in the Lyon region, has been designing and producing **display cases and dispensers** for various business sectors, including the health and convenience store sectors, **since 2007**.

With its products, APPLYMAGE® aims to **showcase its customers' products** for improved marketing.

APPLYMAGE® products are **distributed** directly or via its customers **across all five continents** in over 80 countries.

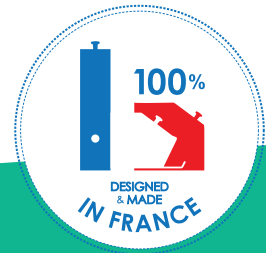

Our approach

APPLYMAGE® and its designers – who have received the "Observateur du Design" award several times – are committed to developing **eco-designed** products that are **made in France**, increasingly **innovative** and **built to last**, and which meet user needs as closely as possible.

APPLYMAGE® invests regularly and heavily in **R&D** and **Intellectual Property** to bring new innovations onto the market each year.

Applymage® Eco

APPLYMAGE® Eco, with its **Applyvrac®** and **Eterniti®** brands, focuses on developing equipment and solutions intended to improve the layout and dynamism of **retail outlets and convenience stores**, especially **organic** and **bulk grocery shops** as well as **hotels** and **homes**.

OVER **17** years
of **experience**

OVER **40,000**
Applyvrac® in service

OVER **600** **grocery**
shops equipped!

registered
brands & trademarks

In France and abroad

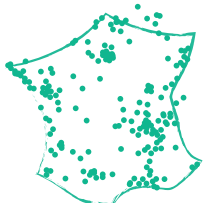

Click here

to see our map of the grocery shops that have placed their trust in us!



APPLYMAGE® Eco

18 rue des Frères Lumière
69680 CHASSIEU - France

+33 (0)9.64.22.06.45
+33 (0)6.73.52.95.77

contact@applymage.com
www.applymage-eco.com